

IDENTIFICATION AND LOCALIZATION OF H⁺-ATPase, NHE2 AND NHE3 IN THE
GILLS OF THE SOUTHERN APPALACHIAN BROOK TROUT, *Salvelinus fontinalis*

A Thesis
by
BRIAN PATRICK MIKEWORTH

Submitted to the Graduate School
Appalachian State University
In partial fulfillment of the requirements for the degree of
MASTER OF SCIENCE

May 2012
Department of Biology

IDENTIFICATION AND LOCALIZATION OF H⁺-ATPase, NHE2 AND NHE3 IN THE
GILLS OF THE SOUTHERN APPALACHIAN BROOK TROUT, *Salvelinus fontinalis*

A Thesis
by
BRIAN PATRICK MIKEWORTH
May 2012

APPROVED BY:

Susan L. Edwards, Ph.D.
Chairperson, Thesis Committee

Ted Zerucha, Ph.D.
Member, Thesis Committee

Gary Walker, Ph.D.
Member, Thesis Committee

Steven W. Seagle, Ph.D.
Chairperson, Department of Biology

Edelma D. Huntley, Ph.D.
Dean, Research and Graduate Studies

Copyright by Brian Patrick Mikeworth 2012
All Rights Reserved

ABSTRACT

IDENTIFICATION AND LOCALIZATION OF H⁺-ATPase, NHE2 AND NHE3 IN THE GILLS OF THE SOUTHERN APPALACHIAN BROOK TROUT, *Salvelinus fontinalis* (May 2012)

Brian Patrick Mikeworth, B.S., Appalachian State University

M.S., Appalachian State University

Chairperson: Susan Edwards

Southern brook trout (*Salvelinus fontinalis*) native to the Great Smoky Mountains are found in headwater streams. These habitats have recently been experiencing increasing instances of stream acidification, lowering stream pH on average ~1.0 pH unit (Deyton et al., 2009). Stream acidification was directly correlated with a decrease in whole-body Na⁺ in southern brook trout, which can cause sub-lethal to lethal stress ultimately resulting in fish mortality (Neff et al., 2009). It is well documented that lowering environmental pH results in fish experiencing systemic acidosis. We hypothesize that during acidification events brook trout are suffering a physiological acid/base perturbation. Previous studies on other species of freshwater fishes have demonstrated an alteration in the relative expression of H⁺-ATPase, NHE2 and NHE3 in gill tissue during pH disturbances (Perry et al., 2000; Hirata et al., 2003; Yan et al., 2007). Due to a lack of physiological information available, the mechanism utilized by *S. fontinalis* to regulate systemic pH is unknown. We hypothesized that *S. fontinalis* will utilize H⁺-ATPase, NHE2 and NHE3 to excrete excess protons when experiencing episodic stream acidification. To date, we have cloned an ORF for H⁺-ATPase (1,376 bp) NHE2 (1,485 bp) and NHE3 (2,100 bp) which are homologous to rainbow trout

(87, 94 and 92% identical respectively). Immunohistochemical analysis demonstrated that H⁺-ATPase, NHE2 and NHE3 expression is localized to the apical membrane and sub-apical regions of the mitochondria-rich cells in gill epithelia. Also, the relative expression of H⁺-ATPase was found to decrease along the elevation gradient, whereas NHE3 does not. This suggests that brook trout regulate H⁺-ATPase expression in response to systemic acidosis, where NHE3 may play a role in Na⁺ absorption.

DEDICATION

I would like to dedicate this thesis to my parents Kevin and Laura Mikeworth, who have aided me in more ways than I could have ever imagined. Thank you for everything.

ACKNOWLEDGMENTS

I would first and foremost like to thank Dr. Sue Edwards for everything she has done to aid in the completion of this thesis as well as my understanding of ion-transport physiology. She believed in my abilities even when lacking, providing mentorship and friendship when needed. Without her, this research could not have been possible. I would also like to thank my Master's thesis committee members, Dr. Ted Zerucha and Dr. Gary Walker for assisting in certain aspects of this research. I also owe thanks to the Office of Student research for funding this research project.

I would like to acknowledge the hard work done by Stephen Moore and Matt Kulp of the Great Smoky Mountains National Park Fisheries department. Without the aid of these men, the current research project would not be possible. Thank you for making the collection of these animals possible.

I would like to show my gratitude to Dr. James B. Claiborne of the Department of Biology at Georgia Southern University for the availability of his sculpin *anti-NHE2* antibody. I would also like to thank Dr. Steven F. Perry of the Faculty of Science at the University of Ottawa for the kind donation of his rainbow trout *anti-NHE3* antibody. Without these antibodies, the majority of this research would not be possible.

Finally, I would like to thank all of my friends and peers who supported me throughout the completion of this project.

TABLE OF CONTENTS

| | |
|---|-----|
| Abstract | iv |
| Dedication | vi |
| Acknowledgments | vii |
| List of Tables | x |
| List of Figures | xi |
| Introduction | 1 |
| Acid-Base regulation in teleost fish | 1 |
| Structure and function of H ⁺ -ATPase | 5 |
| Structure and function of the Na ⁺ /H ⁺ exchanger | 8 |
| Gill morphology of freshwater fish | 12 |
| Southern Appalachian brook trout | 13 |
| Episodic stream acidification | 15 |
| Purpose of study | 17 |
| Methods | 19 |
| Collection of samples | 19 |
| RNA isolation and cDNA synthesis | 19 |
| Polymerase chain reaction (PCR) | 20 |
| Molecular cloning and sequencing | 21 |
| Sequence analysis | 22 |
| Antibodies | 22 |

| | |
|--|----|
| Quantification of relative protein expression | 23 |
| Immunolocalization and fluorescence microscopy | 24 |
| Results | 26 |
| Gene sequencing and annotation | 26 |
| Western blot | 27 |
| Immunohistochemistry | 28 |
| Discussion | 32 |
| Sequenc analysis of H ⁺ -ATPase, NHE2 and NHE3 | 32 |
| Localization of H ⁺ -ATPase, NHE2 and NHE3 in gill MRCs | 34 |
| Utilization of H ⁺ -ATPase, NHE2 and NHE3 in gill epithelia | 38 |
| Pitfalls | 40 |
| Conclusions | 41 |
| Future studies | 42 |
| References | 73 |
| Vita | 81 |

LIST OF TABLES

| | |
|--|----|
| Table 1. Primer sequences used to clone H ⁺ -ATPase..... | 48 |
| Table 2. Primer sequences used to clone NHE2..... | 51 |
| Table 3. Primer sequences used to clone NHE3..... | 54 |

LIST OF FIGURES

| | |
|---|----|
| Figure 1. Osmoregulation in freshwater and seawater adapted fish..... | 43 |
| Figure 2. Current working model for ion regulation in fish gill epithelia..... | 44 |
| Figure 3. Structure and mechanism of H ⁺ -ATPase..... | 45 |
| Figure 4. Structure of Na ⁺ /H ⁺ exchanger isoform -3..... | 46 |
| Figure 5. Model of fish gill epithelia..... | 47 |
| Figure 6. Full-length nucleotide sequence for H ⁺ -ATPase..... | 49 |
| Figure 7. Multiple sequence alignment of H ⁺ -ATPase in teleost fishes..... | 50 |
| Figure 8. Partial open reading from for brook trout NHE2..... | 52 |
| Figure 9. Multiple sequence alignment of NHE2 in teleost fishes..... | 53 |
| Figure 10. Full-length nucleotide sequence for NHE3..... | 55 |
| Figure 11. Multiple sequence alignment of NHE3 in teleost fishes..... | 56 |
| Figure 12. Representative western blot of H ⁺ -ATPase and NHE3 in gill epithelia..... | 57 |
| Figure 13. Relative Expression of H ⁺ -ATPase and NHE3..... | 58 |
| Figure 14. Colocalization of H ⁺ -ATPase and NKA in gill epithelia..... | 59 |
| Figure 15. Immunolocalization of H ⁺ -ATPase in URP brook trout..... | 60 |
| Figure 16. Immunolocalization of H ⁺ -ATPase in MRP brook trout..... | 61 |
| Figure 17. Immunolocalization of H ⁺ -ATPase in LRP brook trout..... | 62 |
| Figure 18. Colocalization of NHE2 and NKA in gill epithelia..... | 63 |
| Figure 19. Immunolocalization of NHE2 in URP brook trout..... | 64 |
| Figure 20. Immunolocalization of NHE2 in MRP brook trout..... | 65 |

| | |
|---|----|
| Figure 21. Immunolocalization of NHE2 in LRP brook trout..... | 66 |
| Figure 22. Colocalization of NHE2 and H ⁺ -ATPase in gill epithelia..... | 67 |
| Figure 23. Colocalization of NHE3 and NKA in gill epithelia..... | 68 |
| Figure 24. Immunolocalization of NHE3 in URP brook trout..... | 69 |
| Figure 25. Immunolocalization of NHE3 in MRP brook trout..... | 70 |
| Figure 26. Immunolocalization of NHE3 in LRP brook trout..... | 71 |
| Figure 27. Co-localization of H ⁺ -ATPase and NHE3 in gill epithelia..... | 72 |

INTRODUCTION

Acid-Base regulation in teleost fishes

The regulation of acid-base balance is imperative for all vertebrates (Claiborne et al., 2002). Fish maintain internal pH in a similar manner to other vertebrates through the utilization of bicarbonate and non-bicarbonate buffers, secreting excess acid and base ions into the external environment, and least effectively by adjusting levels of CO₂ within the plasma through changes in respiration rates (Evans et al., 2005). Because fish are restricted to water, the mechanisms for regulating acid and base relevant ions differ slightly from strategies utilized by terrestrial vertebrates. Teleost fish maintain a homeostatic blood pH ranging from 7.7-8.0 via sensitive physiological mechanisms. These mechanisms function to regulate changes in blood pH resulting from the digestion of nutrients, changes in environmental O₂/CO₂ concentrations and environmental pH (Claiborne, 1998; Evans et al., 2005). Fishes can face a multitude of environmental conditions related to the concentration of O₂ and CO₂ which can drastically alter stream pH. Hyper- Hypoxia describes the relative amount of O₂ available within the environment, where hypoxic conditions will cause an organism to experience acidosis. Hyper- Hypocapnia describes the relative environmental concentration of CO₂, where hypercapnic conditions will also cause an organism to experience acidosis (reviewed in detail by Evans et al., 2005).

Fish lack the ability to compensate pH disturbances by adjusting levels of CO₂ through an “open” CO₂-HCO₃⁻ buffer system as seen in mammals. This refers to the transport of metabolically produced CO₂ leaving through gill/lung epithelia via counter-current gas

exchange (Evans et al., 2005). In fish, arterial plasma partial pressure of CO₂ (P_{CO_2}) and blood bicarbonate levels are similar to that of their environment, resulting in a low P_{CO_2} gradient between the fish's arterial blood and water under normal circumstances. Ultimately this prevents fish from relying on hyperventilation as a means to expel excessive amounts of metabolically produced acids. Most CO₂ excreted from gill epithelia travels through the plasma as HCO₃⁻ ions, which must enter red blood cells (RBC's) via an anion exchanger (Cl⁻/HCO₃⁻) to be converted to CO₂ (Perry and Gilmour, 2002). The rate at which HCO₃⁻ enters the RBC's is found to be relatively slow as well as the conversion of HCO₃⁻ to CO₂ via Carbonic Anhydrase (CAII) (Perry and Gilmour, 2002). This would increase the amount of time it would take to buffer out the plasma during instances of hypercapnic acidosis and decrease its efficiency to regulate acid-base homeostasis (Perry and Gilmour, 2002). These factors together demonstrate that fish cannot rely on respiration as a means to excrete metabolically produced CO₂.

Another means of regulating internal pH changes is by utilizing bicarbonate (HCO₃⁻) and non-bicarbonate buffers (Nbbs) to reduce the amount of free H⁺ in the plasma and intercellular fluid found in blood and tissues (Claiborne, 1998; Evans et al., 2005). Free H⁺ and CO₂ are produced via various cellular metabolic processes, directly affecting inter/extracellular pH. Compensation for changes in systemic pH due to increased levels of CO₂ by utilizing carbonic anhydrase (CAII), a catalytic enzyme that hydrates CO₂ to produce H⁺ and HCO₃⁻ ions ($CO_2 + H_2O \leftrightarrow H^+ + HCO_3^-$; Henry, 1996; Claiborne et al., 2002). Bicarbonate ions then act to buffer plasma by taking up free H⁺, thus reducing levels of free H⁺ and raising plasma pH (Claiborne et al., 2002). Although fish are able to compensate for slight changes in systemic pH through the utilization of a plasma buffering mechanism, they

have a relatively low amount of HCO_3^- and NH_4^+ within the plasma and must rely on the excretion of relevant acid-base ions (H^+ , OH^- , HCO_3^- , and NH_4^+) through epithelial tissue (gills, kidneys, intestines, and skin) (reviewed in Evans et al., 2005). Therefore, the primary mechanism by which fish regulate internal pH is through the excretion of H^+/NH_4^+ linked to the transepithelial uptake of Na^+ ions from the external environment and that the secretion of $\text{HCO}_3^-/\text{OH}^-$ linked to the transepithelial uptake of Cl^- (Krogh, 1937; Garcia-Romeu and Maetz, 1964; Kerstetter et al., 1970; Claiborne et al., 2002). This suggests that acid-base regulation in fish is sensitive to environmental salinity.

Acid-Base regulation in freshwater fish

Since Krogh (1937), the role of environmental salinity in acid-base homeostasis has been extensively studied. Freshwater environments are considered hypotonic to fish. Due to a higher internal osmolarity than that of their surrounding environment, freshwater fish are constantly losing salts to their environment while simultaneously absorbing water (Figure 1). To combat the loss of ions, the animal actively absorbs ions across gill and kidney epithelia, while excreting water through producing copious amounts of dilute urine (Krogh, 1937). In a later investigation, Maetz and Garcia-Romeu (1964) examined the coupling of Na^+ and Cl^- uptake by radioisotope flux NH_4 and HCO_3^- in gill epithelia. They discovered that Na^+ uptake was directly affected in the presence (external and internal) of NH_4 , but Cl^- uptake was not affected. The same was seen when Cl^- uptake was examined using HCO_3^- flux, where Cl^- uptake was directly affected in the presence of HCO_3^- and Na^+ uptake was not affected. These findings by Maetz and Garcia-Romeu (1964) suggest the presence of a $\text{Na}^+/\text{NH}_4^+$ exchanger as well as a $\text{Cl}^-/\text{HCO}_3^-$ exchanger, which acts in the separate uptake of Na^+ and Cl^-

ions from the environment. A more thorough investigation into the correlation between $\text{Na}^+/\text{NH}_4^+$ uptake in the gills in freshwater rainbow trout led to the finding that Na^+ uptake is more directly associated with H^+ extrusion rather than ammonia, which would suggest that the $\text{Na}^+/\text{NH}_4^+$ exchanger would be in fact a Na^+/H^+ exchanger (NHE) (Avella and Bornancin, 1989). This model was not disputed until Lin and Randall (1991) used a known blocker of NHE and ENaC, 0.5mM Amiloride, to inhibit Na^+ uptake in gill epithelia. The results of this study showed that Na^+ uptake was blocked while H^+ excretion remained, therefore providing the physiological evidence for the presence of an H^+ -ATPase transporter protein in gill epithelia (Lin and Randall, 1991). Further studies by Lin and Randall (1993) determined the role of H^+ -ATPase in Na^+ uptake by using the H^+ -ATPase inhibitor bafilomycin. Taken together, there are two proposed mechanisms for Na^+ uptake and H^+ excretion from the gills of freshwater adapted fish, either by means of a NHE or through an H^+ -ATPase and an epithelial Na^+ channel (ENaC) (Goss et al., 1998). The current working model for ion regulation in gill epithelia of freshwater-adapted fish suggests the apical localization of H^+ -ATPase and a proposed ENaC to both MRCs and PVCs (Figure 2; Lin and Randall, 1993; Laurent et al., 1994; Goss et al., 1998; Claiborne et al., 2002). These mechanisms would allow for fish to maintain a homeostatic systemic pH while regulating internal osmolarity. Current data suggests that freshwater adapted fish do regulate specific isoforms of NHE within the gill, suggesting that active secretion of H^+ is not the sole mechanism responsible for maintaining osmolarity as well as systemic pH.

Structure and function of H⁺-ATPase

H⁺-ATPase is a multi-subunit complex that is found in either the membranes of organelles or implanted in the plasma membrane (Jefferies et al., 2008). The protein complex is composed to two structurally distinct functional domains, V₁ and V₀ (Figure 3). The 700-kDa V₁ complex is assembled and located within the cytosol and is composed of eight subunits (A₃, B₃, C, D, E₂, F, G₂ and H) that are responsible for ATP hydrolysis (Arai et al., 1988; Jefferies et al., 2008; Ma et al., 2011). The 250- kDa V₀ subunit complex is composed of six subunits (a, c₄, c', c'', d and e) and is responsible for proton transport across a membrane (Arai et al., 1988; Jefferies et al., 2008; Ma et al., 2011). H⁺-ATPase is remarkably similar to F-type ATPase in both structure and function by utilizing a rotary mechanism activated via ATP hydrolysis to facilitate proton efflux (Jefferies et al., 2008; Zhang et al., 2008).

Physiological function of H⁺-ATPase in mammals

H⁺-ATPase is found in the plasma membrane of many types of eukaryotic cells, where it plays a specific physiological role in regulating systemic/cytosolic pH as well as acidifying the extracellular lumen. One of the most well studied roles of H⁺-ATPase in the plasma membrane is in the mammalian kidney and its role in filtering blood and excreting waste products as well as regulating acid-base balance. Renal intercalated cells have been separated into two cell types, alpha-intercalated cells (A-IC) and beta-intercalated cells (B-IC). Both cell types act in a similar manner where A-IC are responsible for acid secretion and B-IC are responsible for base secretion (Brown et al., 2009). H⁺-ATPase has been localized to the apical membrane of the A-IC cells mainly found in the distal tubule and the collecting

duct suggesting its importance in acid secretion (Brown et al., 1988; Brown et al., 2009). Intercalated cells respond to systemic acid-base disturbances by converting HCO_3^- to diffusible CO_2 via catalytic carbonic anhydrase and excreting H^+ across the apical membrane into the lumen. In response to systemic acidosis, A-IC increase the expression of apically localized H^+ -ATPase and basolateral localized $\text{Cl}^-/\text{HCO}_3^-$ exchanger (Brown et al., 1988; Brown et al., 2009). This would prove optimal for excretion of excess H^+ as well as reabsorption of HCO_3^- . In response to systemic alkalosis, apical expression of H^+ -ATPase is decreased and is found in the basolateral membrane of B-ICs. This would allow for the movement of H^+ into the plasma to bind excess HCO_3^- lowering systemic pH to homeostatic conditions (Brown et al., 2009). Mutations in the B1 subunit (plasma membrane associated) leads to distal renal tubular acidosis, where the kidneys are not able to properly rid the body of acids by acidifying the urine (Finberg et al., 2005). Knock-out studies in mice have shown that isoform B1 is specifically associated with apical proton excretion in response to systemic acidosis. In the absence of the B1 isoform, the B2 isoform (organelle associated) responds by implanting into the plasma membrane to excrete H^+ apically, but is found to be less effective (Finberg et al., 2005; Brown et al., 2009).

Physiological function of H^+ -ATPase in teleost fishes

Similar to the role in the mammalian kidney, H^+ -ATPase plays a significant role in Na^+ absorption and acid-base regulation in the gills and kidneys of freshwater fish. It is suggested that H^+ -ATPase is electrogenically coupled with ENaC on the apical membrane of ion transporting cells in the gills and kidneys of freshwater adapted fish. These specialized cells are known as mitochondrion-rich cells (MRCs) and pavement cells (PVCs) (Evans et

al., 2005). The apical localization of these ion transporters would allow for the active excretion of H^+ ions driving the passive influx of Na^+ . This was confirmed by Lin et al. (1994) and Sullivan et al. (1995) who probed gill tissue sections with heterologous antibodies specific to H^+ -ATPase in rainbow trout and detected concentrated expression on the apical membrane of mostly MRCs and few PVCs.

Until recently, very little molecular data existed for teleost fishes as H^+ -ATPase had primarily been investigated in mammals. Using a cDNA library created from the gills of rainbow trout (*Oncorhynchus mykiss*), Perry et al. (2000) cloned the B-subunit of H^+ -ATPase that demonstrated a similar identity to the mammal isoform found in the brain. However, to date there is still no evidence of an ENaC like Na^+ transporter in any of the published fish genomes. Perry et al. (2000) also sought to characterize H^+ -ATPase in freshwater fish through investigating H^+ -ATPase expression in response to hypercapnic acidosis in rainbow trout. They determined that H^+ -ATPase mRNA expression increased ~5-70 fold, increasing H^+ excretion and returning systemic pH to a homeostatic state. More recently, zebrafish embryos are found to have strong expression of H^+ -ATPase in embryo epidermal cells (termed H^+ -rich cells, HR) and in the yolk sack. Exposure of these embryos to acidic freshwater (4.0 pH) resulted in a significant increase in H^+ -ATPase expression within gill cells, suggesting that zebrafish utilize H^+ -ATPase to excrete H^+ . Using transgenic techniques to knockdown H^+ -ATPase expression in HR cells, researchers reported inhibition of both H^+ efflux and Na^+ absorption (Yan et al., 2007). These studies together provide genetic and physiological evidence that H^+ -ATPase plays a specific role in H^+ excretion and Na^+ absorption in freshwater fish. This mechanism makes thermodynamic sense due to the dilute environment in which freshwater fish are found, where environmental Na^+ concentrations are

too low for fish to effectively rely on passive exchange via Na^+/H^+ exchanger (Evans et al., 2005).

Structure and function of the Na^+/H^+ exchanger

The Na^+/H^+ exchanger (NHE) is a family of membrane transport proteins that play a role in many physiological mechanisms, specifically those regarding Na^+ absorption and H^+ excretion. Structurally NHEs generally contain 12 membrane-spanning domains (M1-M12) located at the N-terminus followed by a cytosolic C-terminus tail. The membrane-spanning segments at the N-terminus mediate trans-membrane cation ($\text{Na}^+/\text{NH}_4^+$ and H^+) exchange while the C-terminus tail is thought to regulate function in response to changes in intracellular osmolarity and pH (Orlowski and Grinstein, 2004; Alexander et al., 2011). Functional studies discovered that the M4 domain specifically binds and transports either Na^+ or NH_4^+ (Touret et al., 2001) where domain M7 binds and translocates H^+ (Slepkov et al., 2005). Na^+/H^+ exchangers function to exchange extracellular Na^+ for intracellular H^+ at a 1:1 stoichiometric ratio, where Na^+/H^+ exchange is driven by a steep inward Na^+ gradient created by basolaterally localized Na^+/K^+ -ATPase (Hirata et al., 2003; Alexander and Grinstein, 2009).

Physiological function of NHE 2/3 in mammals

The Na^+/H^+ exchanger protein belongs to the mammalian SLC9A family of genes, where to date, a total of nine isoforms have been discovered in mammals (extensively reviewed by Orlowski and Grinstein, 2004). The NHE2 isoform is found in a number of tissues in mammals, such as skeletal muscle, colon, intestine and most importantly the

kidneys, where they play a functional role in Na^+ absorption and H^+ excretion (Malakooti et al., 1999). Within the kidney, NHE2 is expressed mainly in the cortical thick ascending limb, distal convoluted tubule and the connecting tubules (reviewed in Orłowski and Grinstein, 2004). NHE isoform 3 is generally only found in renal and gastrointestinal tissues, where it plays a key role in Na^+ /water absorption as well as regulating systemic pH through H^+ excretion. Similar to the role of H^+ -ATPase in renal intercalated cells, NHE2 and NHE3 are found to specifically regulate systemic pH homeostasis through altering the relative expression in the cell. Early immunolocalization studies probed with a monoclonal antibody specific to NHE3 resulting in the apical localization of NHE3 within the nephron of neonatal and adult rats (Biemesderfer et al., 1997). This study demonstrated apical expression of NHE3 in the nephron and collecting ducts in the rat kidney, further suggesting that NHE3 plays a key role in filtering blood by absorbing Na^+ and regulating plasma pH by excreting intracellular H^+ . Schultheis et al. (1998) later confirmed this model by using transgenic studies to knockout NHE3 expression in mice. NHE3-null mice experienced low blood pressure and diarrhea, suggesting that NHE3 is required for Na^+ absorption in the renal and gastrointestinal tract. NHE3-null mice also experienced a relatively acidic plasma pH, suggesting further that NHE3 plays a key role in regulating systemic pH (Schultheis et al., 1998). In contrast to this, NHE2-null mice experienced no defects in intestinal or renal Na^+ absorption (Ledoussal et al., 2001). They suggest that NHE2 plays a small role in regulating plasma osmolarity and acid-base balance, while NHE3 is utilized in the mammalian kidney.

Physiological function of NHE2/3 in teleost fishes

The Na⁺/H⁺ exchanger in teleost fishes plays a parallel role in Na⁺ uptake, fluid absorption and acid-base regulation as seen in mammals. Unlike mammals, teleost fish face a wide variety of salinities requiring different physiological mechanisms to regulated plasma osmolarity and acid-base balance. To date, only NHE isoforms 1, 2 and 3 have been discovered in multiple fish species, where function is conserved and regulation is generally species specific (Claiborne et al., 1999; Edwards et al., 1999; Wilson et al., 2000a; Wilson et al., 2000b; Edwards et al., 2002; Hirata et al., 2003; Edwards et al., 2005; Edwards et al., 2010). Early work by Edwards et al. (1999) discovered an NHE3-like protein in the gills of rainbow trout (*Oncorhynchus mykiss*) and the blue-throated wrasse (*Pseudolabrus tetrivus*) by using heterologous antibodies to label NHE3-like expression to MRCs. Similar results were reported in the localization of NHE3 in the gills of mudskipper (Wilson et al., 2000b), suggesting that NHE3 is actively transcribed in the MRCs of freshwater fish and possibly facilitates Na⁺ absorption or H⁺ excretion in gill epithelia.

Although much work has been accomplished in characterizing NHE3 within teleost fishes, little physiological information is available on the NHE2 within teleost fishes. Early immunological detection using mammal-specific NHE2 antibodies determined that NHE2 proteins are localized to the apical membrane and within the cytoplasm of MRCs in multiple elasmobranch species (banjo ray (*Trygonorrhina fasciata*), southern eagle ray (*Myliobatis australis*) and angel shark (*Squatina australis*); Edwards et al., 2002) and in the spiny dogfish (Claiborne et al., 2008). Although coexpression of NHE2 and Na⁺/K⁺-ATPase in the MRCs suggests a functional role for NHE2 in Na⁺ uptake and H⁺ excretion, it was found that acidotic dogfish do not alter gill NHE2 mRNA and therefore do not utilize NHE2 for proton

excretion (Claiborne et al., 2008). Different results were seen in the longhorn sculpin (Catches et al., 2006). Although sculpin similarly express NHE2 in the apical membrane of gill MRCs, they do significantly increase NHE2 transcripts following systemic acidosis (Catches et al., 2006). These studies together suggest that marine teleost fishes may utilize NHE2 in gill tissue to regulate systemic pH when faced with acid perturbations although NHE2 may be differentially expressed among marine organisms. It was reported that the freshwater adapted killifish increases mRNA expression of NHE2 rather than NHE1/3 when experiencing environmental hypercapnia (Edwards et al., 2005). Similar results were seen by Ivanis et al. (2008) where NHE2 and not NHE3 mRNA expression was increased in hypercapnic rainbow trout. The same study also localized NHE2 mRNA transcripts and NHE3 protein expression to PNA⁺ MRCs in gills, suggesting that rainbow trout excrete H⁺ via NHE2 from the gills when experiencing hypercapnic conditions. These studies together suggest that NHE2 plays an important role in acid secretion in freshwater adapted fish and not NHE1 or NHE3.

Interestingly, the Osorezan dace (*Tribolodon hakonensis*) known to inhabit rather acidic conditions (pH of 3.5) is found to regulate NHE3 in gills, suggesting its role in regulating acid-base balance (Hirata et al., 2003). Similar to the Osorezan dace, the Mozambique tilapia (*Oreochromis mossambicus*) also inhabits acidic waters (pH 4.0). NHE3 expression is localized to the apical membrane of MRCs in gill epithelia and is significantly increased during acid perturbation (Watanabe et al., 2008; Furukawa et al., 2011). More recently, medaka (*Oryzias latipes*) are also found to increase relative mRNA expression of NHE3 in the response to acclimation of acidic freshwater (Lin et al., 2012). Taken together, NHE2 and NHE3 are differentially regulated across teleost species to function specifically

for Na^+ uptake or H^+ excretion. Therefore, further investigations are required in an increased number of teleost species.

Gill morphology of freshwater fish

The gills of teleost fishes encompass eight gill arches covered by a small bony flap called the operculum. Each gill arch supports many long fleshy filaments, each of which is intricately folded into smaller projections termed lamellae, in which water can pass across. Gill epithelia are composed of two primary cell types: Pavement cells (PVCs) and Mitochondrion-rich cells (MRCs) located on the lamellae and in the interlamellar region (Figure 4). Pavement cells have been found to be important in respiration and ion regulation, and are typically found along the lamellae and within the interlamellar region (Laurent et al., 1994). Mitochondria-rich cells are considered to be the primary site for ion transport in fish and are only found within the interlamellar region on the outer epithelia of the filament (Evans et al., 2005). They are rich in mitochondria and are able to produce large amounts of ATP, which is then used by transepithelial transporter proteins in osmoregulation in the regulation of systemic pH and in ammonia excretion. Goss et al. (2001) provided evidence for the presence of a sub-population of PVCs in the gills of rainbow trout based on the positive binding of peanut lectin agglutinin (PNA). It is reported that PNA binds to cells with similar morphology to MRCs (termed PNA^+ or β -MRC) and where PNA binding is absent (termed PNA^- or α -MRC) (Goss et al., 2001). Galvez et al. (2002) followed up this work with the intent to characterize these sub-populations of MRCs. PNA^- cells were typically found along the distal and basal ends of the lamellae and not in the interlamellar regions. In addition, PNA^- cells exhibited an elevated expression of H^+ -ATPase and Na^+/K^+ -

ATPase in response to systemic acidosis, associating these cells with acid excretion. Galvez et al. (2002) also reported that PNA⁺ cells were located along the basal surface of the lamellae and within the interlamellar region and were physically covered by PVCs when experiencing acidosis. PNA⁺ cells were later established as base secreting cells, as the Cl⁻/HCO₃⁻ exchanger was immunolocalized to the apical membrane and H⁺-ATPase localized to the basolateral membrane, associating these cells with base secretion (Perry et al., 2003). It is now generally accepted that α -MRCs are associated with acid secretion and β -MRCs are associated with base secretion, although Ivanis et al. (2008) reported that NHE3 expression was only localized to the apical membrane of the β -MRCs and not the α -MRCs. Thus the definition of either sub-cellular type must be investigated further.

Southern Appalachian brook trout

Southern brook trout (*Salvelinus fontinalis*) are in fact closely related to the arctic char rather than trout. Southern brook trout are members of the Salmonidae family (Actinopterygii: Salmoniformes: Salmonidae: *Salvelinus*). Dating back to the late 1800's during a period of heavy logging and clear cutting in the southern Appalachian mountain range, it was noted that brook trout populations were devastated due to over sedimentation and pollution of their native streams (Karas, 1997). The clearing of trees from the stream banks, introduction of sediments, and runoff of chemicals from various sources of pollutants (vehicles, pesticides, and fertilizers) changed the composition of the streams and have caused many native southern brook trout populations to decline, many of which have been locally extirpated (Neff et al., 2009). In an effort to repopulate southern brook trout in their native streams, managers attempted to raise small populations of them in hatcheries and restock the

previously damaged streams. Native southern brook trout were found to have trouble reproducing successfully and surviving in hatchery conditions, as they were found to be more susceptible to hatchery diseases (Karas, 1997). Thus a new approach was needed to reverse the population decline of this species. The hatcheries decided to look at the northeastern United States (Michigan, New York, and Pennsylvania) in an attempt to raise populations of northern brook trout (McCracken, 1993). This proved to be successful. The hatchery-reared northern brook trout as well as non-native rainbow trout and European brown trout were then used to restock streams where populations of native southern brook trout have faced local extirpation (Karas, 1997). Years after restocking streams with the hatchery-raised northern brook trout, the local fisherman began to notice a visual/morphological difference between the native southern brook trout and the stocked northern brook trout. Native southern brook trout are ~10cm long at full maturity with red speckles running along the lateral line and bright red bellies during spawning season. The hatchery-raised northern brook trout grow to sizes ranging from 25-65cm and are drab in color, lacking both the strong red speckles and bellies. In addition to the morphological differences, genetic studies have demonstrated that northern brook trout are genetically distinct from the native southern brook trout (McCracken et al., 1993).

Today, southern brook trout populations can be found in the streams, creeks, lakes and springs along the southern Appalachian Mountain range in the Great Smoky Mountains National Park (GRSM) (Bivens et al., 1985). These fish are western North Carolina's only native trout and are a valuable asset to Appalachian Mountains as well as the local populous. Native southern brook trout are found only in high-elevation headwater streams that are extremely soft (Average Na: 29.6 $\mu\text{eq/L}$, Cl: 11.81 $\mu\text{eq/L}$, NH_4^+ : 0.56 $\mu\text{eq/L}$, Ca: 50.42 $\mu\text{eq/L}$,

Mg: 24.82 $\mu\text{eq/L}$, K: 9.64 $\mu\text{eq/L}$, Al: 0.09 ppm, NO_3 : 43.6 $\mu\text{eq/L}$, and SO_4 : 44.85 $\mu\text{eq/L}$; Deyton et al., 2009). These headwater streams can face extreme changes in water chemistry over short periods of time, specifically acute drops in pH (~ 1 pH unit) (Deyton et al., 2009; Neff et al., 2009). Most importantly, these fish are found to inhabit streams that are relatively acidic (5.0-6.5 pH) throughout all seasons (Cook et al., 1994).

Episodic stream acidification

Episodic stream acidification is described as an acute drop in water pH and a reduction of the streams ability to neutralize acid ions (Deyton et al., 2009). These events are caused by acid deposition directly into streams and in forested watersheds by acid rain. Acid rain has been characterized as large quantities of sulfates and nitrates being deposited into the atmosphere by coal-burning power plants and emissions from vehicles (Herlihy et al., 1990). During an acid rain event in a forested watershed, sulfates have been found to be the most abundant acidic anion deposited into soils and streams, while nitrate anions were second highest (Cai et al., 2010). Sulfates have been found to be the main cause of acute stream acidification during stormflow events in the southern Appalachian Mountains (Deyton et al., 2009). Because the retention of sulfates in soils is dependent on soil quality (adsorption-desorption), higher concentrations of sulfates have been found at higher elevations (Evans et al., 1997; Driscoll et al., 2001; Mitchell et al., 2001). Nitrates act in a similar manner as sulfates by only being retained through soil adsorption. Although, nitrates have a slightly better soil retention rate than sulfates and can be taken up readily by forest vegetation, nitrates can also be deposited into soil by forest vegetation by nitrification, or the conversion of ammonia anions (deposited through acid rain events) to nitrate anions. Concentrations of

both sulfates and nitrates build up over long, dry periods in the soil and are eventually exported to streams via stormflow events; this is what is believed to cause episodic stream acidification (Deyton et al., 2009). Another cause of streams to become acidified is the loss of buffering cations (Ca^{2+} , Mg^{2+} , and Na^{+}) due to an overabundance of acidic anions and also stormflow events, which would ultimately decrease the buffering capability of the stream (or Acid Neutralizing Capability, ANC) (Dambrine et al., 1998; Castro and Morgan, 2000; Cai et al., 2010).

Episodic stream acidification in the Great Smoky Mountains National Park

The Great Smoky Mountains National Park (GRSM) is currently faced with the problem of increased acid rain deposition and runoff as well as poor soil buffering capacity (Deyton et al., 2009). This has been shown to result in acute acidification events in high elevation headwater streams (Deyton et al., 2009). The acidification of these streams was first discovered in 1985, through a study measuring the ANC of several high-elevation streams in the GRSM (Cook et al., 1994). This was the first investigation into the impacts of acute stream acidification events and the species it affected. Episodic stream acidification events in the GRSM are caused by two major factors: an increase in acidic ions (sulfates and nitrates) deposited into streams by stormflow events and the reduction of the stream's ANC and pH (Deyton et al., 2009). During a recent study conducted by Deyton et al. (2009), an increase in the deposition of sulfates and nitrates resulted in a drop in ANC and pH of high elevation headwater streams in the GRSM. The study examined three different watersheds and found that there was a difference in the reduction of stream ANC and pH between the three sites. The average drop in pH during these stormflow events was found to be ~0.90 pH

units (Deyton et al., 2009). Acute drops in stream pH can cause distress in stream inhabitants through physiological responses as well as hindering reproductive capabilities (Neff et al., 2009). The southern brook trout has been found to experience local extirpation in certain affected streams (Neff et al., 2009). A study done to investigate the correlation between acute stream acidification and southern brook trout extirpation has discovered that as stream pH dropped so did whole-body Na^+ levels, which can cause sub-lethal stress and eventually mortality in fish (Neff et al., 2009). This study also recorded the pH of the streams the southern brook trout were collected from to be on average below pH 4.5 five times during a six-month period. This would suggest that the relative pH of streams in the GRSM where southern brook trout populations can be found are regularly acidified. It has been shown that in a laboratory behavioral study that *S. fontinalis* will avidly avoid waters with an ambient pH of 5.0 or lower and seek refuge in water with a neutral pH (Newman and Dolloff, 1995). This suggests that southern brook trout prefer relatively neutral waters although they do possess a tolerance for acidic water conditions. Due to the lack of physiological information available, investigation into acid tolerance must be done to determine if stream acidification is a major contributor to the recent population declines and extirpation of southern brook trout from the GRSM.

Purpose of the Study

The purpose of this study is to identify and localize the acid excretion mechanisms in the gills utilized by southern Appalachian brook trout to regulate acid-base homeostasis. Neff et al. (2009) reported that stream acidification in the GRSM caused a decrease with whole-body Na^+ in southern Appalachian brook trout, which caused sub-lethal to lethal stress. We

hypothesize that these fish experience systemic acidosis when acclimating to acidic conditions associated with stream acidification events. It has been shown that freshwater fish acclimated to acidic waters alter the relative expression of H⁺-ATPase, NHE2 and NHE3 in the gill epithelia (Perry et al., 2000; Hirata et al., 2003; Yan et al., 2007; Ivanis et al., 2008; Furukawa et al., 2011). Although these fish species regulate both H⁺-ATPase and NHE3 to excrete excess acids from gill epithelia, the relative expression patterns of these ion-transporters differ between all species investigated. Therefore, we hypothesize that southern Appalachian brook trout utilize H⁺-ATPase, NHE2 and NHE3 to excrete excess acids when faced with stream acidification events. To determine this, I have used molecular biology and protein biochemistry to analyze the distribution and relative expression of both of these ion transporter proteins in the gills of southern Appalachian brook trout.

METHODS

Collection of samples

Southern brook trout (*Salvelinus fontinalis*; 8-40 g n = 18) were obtained from Road Prong Stream in the Great Smoky Mountains National Park, Gatlinburg, TN in July 2011. Animals were collected from three elevations (upper road prong, URP = 1460 m; middle road prong, MRP = 1267 m; and lower road prong, LRP 1195 m) using standard electroshocking techniques (AC, 600-650V, 1-1.5A; Reynolds 1996). All sample fish were anesthetized with MS-222 (0.05%) and killed via spinal pithing. Gill samples were removed and either flash frozen in liquid nitrogen or fixed in 4% paraformaldehyde (pH 7.3).

RNA isolation and cDNA synthesis

Total RNA was isolated from the gills of brook trout using Tri-Reagent® as per manufacturers protocol (Molecular Research Center, Inc. Cincinnati, Ohio) Total RNA was solubilized in DEPC treated RNA/DNase free water and checked for purity and concentration using Nanodrop spectrophotometry at 260/280 nm. First-Strand cDNA was synthesized from 5 µg of total RNA using SuperScript III reverse transcriptase and Oligo-dT primers (Invitrogen, Oregon, USA).

Polymerase chain reaction (PCR)

H⁺-ATPase

Three sets of heterologous primers were designed for rainbow trout, *Oncorhynchus mykiss* H⁺-ATPase (GenBank Ascension number: AF140022.1, Table 1). Polymerase Chain Reaction (PCR) was performed with the following mixtures (50µl): 10 X PCR buffer (no MgCl), 50mM MgCl, 10mM dNTP mix, 10 µM Forward and Reverse primers, template cDNA, and Platinum Taq DNA polymerase (Invitrogen, Oregon, USA). Thermal cycling parameters consisted of an initial activation of *Taq* at 94°C (2 min), 35 cycles of 94°C for (30 sec), 57°C for (30 sec), and 72°C for 2 min and a final extension at 72°C for 10 min. PCR products were analyzed by gel electrophoresis (1% agarose in a 1 x TBE buffer, 45mM Tris borate, 1mM EDTA) stained with ethidium bromide and viewed using UV light.

NHE2

Three sets of heterologous primers were designed for rainbow trout, *Oncorhynchus mykiss* NHE2 (GenBank Ascension number: NM_001130994.1; Table 2). Polymerase Chain Reaction (PCR) was performed with the following mixtures (50µl): 10 X PCR buffer (no MgCl), 50mM MgCl, 10mM dNTP mix, 10µM Forward and Reverse primers, template cDNA, and Platinum Taq DNA polymerase (Invitrogen, Oregon, USA). Thermal cycling parameters consisted of an initial activation of *Taq* at 94°C (2 min), 35 cycles of 94°C for (30 sec), 58°C for (30 sec), and 72°C for 2 min and a final extension at 72°C for 10 min. PCR products were analyzed by gel electrophoresis (1% agarose in a 1 x TBE buffer, 45mM Tris borate, 1mM EDTA) stained with ethidium bromide and viewed using UV light.

NHE3

Four sets of heterologous primers were designed against rainbow trout, *Oncorhynchus mykiss* NHE3 (GenBank Ascension number: NM_001130995.1; Table 3). Polymerase Chain Reaction (PCR) was performed with the following mixtures (50µl): 10 X PCR buffer (no MgCl), 50mM MgCl, 10mM dNTP mix, 10µM Forward and Reverse primers, template cDNA, and Platinum Taq DNA polymerase (Invitrogen, Oregon, USA). Thermal cycling parameters consisted of an initial activation of *Taq* at 94°C (2 min), 35 cycles of 94°C for (30 sec), 54 or 57°C for (30 sec), and 72°C for 2 min and a final extension at 72°C for 10 min. The annealing temperature of each primer varied between 54 or 57°C (table 3). PCR products were analyzed by gel electrophoresis (1% agarose in a 1 x TBE buffer, 45mM Tris borate, 1mM EDTA) stained with ethidium bromide and viewed using UV light.

Molecular cloning and sequencing

Cloning experiments were run via TOPO-TA Cloning kit® following protocol (Invitrogen, Oregon, USA). PCR products of the correct size were ligated into PCR2.1 plasmid vector and transformed into OneShot® TOP10 Chemically competent *E. coli* cells. Transformed cells were plated onto LB/AMP plates (40% LB agar with 0.1% ampicillin) and grown overnight at 37°C. Positive clones were picked with a sterile pipette tip and placed into 14mL polypropylene culture tubes with 5mL LB/AMP broth (2% LB broth with 0.1% Ampicillin), vortexed and shaken at 37°C at 200rpm overnight. Plasmid DNA was isolated via FastPlasmid™ kit (5 Prime Inc., Gaithersburg, MD) following manufacturer protocol and analyzed by restriction digest using *EcoR1* and agarose gel electrophoresis. Clones

containing inserts of the correct size were sequenced on an Applied Biosystems 3100 model DNA sequencer (Mount Desert Island Biological Laboratory DNA sequencing facility).

Sequence analysis

Open reading frame (ORF) construction, sequence annotation and translation were performed using MacVector (MacVector, Inc., North Carolina, USA). BLASTx searches using the GenBank database were performed to acquire similar gene and protein sequences used for analyzing identity and similarity across teleost fishes. Similar protein sequences were aligned using ClustalW using base settings via MacVector.

Antibodies

H⁺-ATPase

Commercially produced monoclonal mouse anti-H⁺-ATPase (V-ATPase 60kDa subunit in yeast; Invitrogen, Oregon, USA) heterologous antibodies were used to study H⁺-ATPase protein localization and expression. These antibodies have been used to determine the localization of the H⁺-ATPase 60-kDa subunit B in yeast (Kane et al., 1992).

NHE2

A polyclonal antibody raised in rabbit against sculpin NHE2 (A94-APS: Ac-CVDNEHGSADNFRDGH-amid; GenBank accession number: AAD46576.2) was used to determine NHE2 protein localization and expression in the gills of southern brook trout. This antibody was a gift from Dr. James B. Claiborne, Department of Biology at Georgia Southern University, Statesboro, GA USA. This antibody was previously used to determine

NHE2 localization and expression in the gills of the marine teleost, *Myoxocephalus octodecemspinosus* (Catches et al., 2006).

NHE3

A polyclonal antibody raised in rabbit against rainbow trout NHE3 (ETKADVDFNKKFRAAS, ABO32815) was used to determine NHE3 protein localization and expression. This antibody was a gift from the Dr. Steven F. Perry, Department of Science University of Ottawa, Canada. These antibodies have been used to determine localization and relative expression of NHE3 in the gills of *O. mykiss* (Ivanis *et al.*, 2008).

Na⁺/K⁺-ATPase

A mouse monoclonal antibody ($\alpha 5$) raised against the $\alpha 1$ subunit of chicken Na^+/K^+ -ATPase was developed by Dr. Douglas Fambrough and obtained from the Developmental Studies Hybridoma Bank. This antibody was used to determine Na^+/K^+ -ATPase localization and expression in the gills of rainbow trout (Ivanis *et al.*, 2008).

Quantification of relative protein expression

Frozen gill tissues were homogenized in homogenization buffer (0.18g Tris-base, 4.28g sucrose, 0.5ml 100mM EDTA, pH 7.8). Total protein samples were quantified via BCA protein assay (Thermo Scientific, Rockford, IL). Total protein samples (50 μg) were separated via SDS-PAGE and transferred to Immobilon-P polyvinylidene difluoride membrane (Millipore). Membranes were blocked in 5% blotto (5% nonfat dry milk powder, 0.1M Tris-buffered saline with Tween-20; 0.2% (TBST)) overnight at 4°C. Blots were then incubated in primary antibody (H^+ -ATPase, 1:4000; NHE2, 1:1000; NHE3, 1:1000) in 5%

blotto overnight, rocking at room temperature. Following three washes with 1 x TBST, blots were incubated with a Horseradish peroxidase-conjugated secondary antibody (H⁺-ATPase: Goat anti-Mouse HRP 1:15,000; NHE2: Goat anti-Rabbit HRP 1:10,000; NHE3: Goat anti-Rabbit HRP 1:10,000) with Precision Protein Plus StrepTactin-HRP conjugate in 1 x TBST, rocking for 1 hour at room temperature. After three additional washes in 1 x TBST and a final wash in 1 x TBS, bound IgG was detected using an enhanced chemiluminescence system (BioRad, California, USA). Membranes were then exposed to and developed on X-ray film (Amersam Hyperfilm ECL). A digitized image was produced by scanning in the film paper and analyzed using QuantityOne® software (BioRad, California, USA). Statistical significance was determined by one-way ANOVA and two-way ANOVA using Microsoft Excel 2007 and Sigmaplot ($P = < 0.05$). Relative protein expression is reported as density of pixels.

Immunolocalization and fluorescence microscopy

Gills were fixed in 4% paraformaldehyde (PFA), dehydrated through a series of increasing ethanol dilutions (50%-100%), cleared in xylene and embedded in paraffin wax using a Shandon Citadel 1000 (Thermo Scientific, Rockford, IL). Embedded tissues were positioned in paraffin blocks for cross-sectioning using a Tissue Embedding Center EC 350 (Microm International). Paraffin blocks were sectioned (7µm) longitudinally on a Leica RM2124 RTS microtome and baked on positively charged slides (VWR VistaVision™ HistoBond® VWR International). Sections were deparaffinized and rinsed in phosphate-buffered solution (1 x PBS) followed by blocking in 5% Natural Goat Serum solution (NGS diluted in phosphate-buffered solution with Triton X-100, 1 x PBST) overnight in a humidity

chamber at room temperature. Sections were incubated with a primary antibody (H^+ -ATPase, 1:500; NHE2 or A94, 1:250; NHE3, 1:1000; NKA or $\alpha 5$, 1:500) in 5%NGS in 1 x PBST overnight in a humidity chamber at room temperature. Following three washes with 1 x PBS, sections were incubated with a fluorescently tagged secondary antibody (AlexaFluor 488 Goat anti-Mouse IgG, AlexaFluor 546 Goat anti-Rabbit IgG, or AlexaFluor 568 Goat anti-Mouse IgG; 1:2000) 1 x PBS for 1 hour in a humidity chamber at room temperature. Following three final washes in 1 x PBS, sections were mounted with Prolong Gold® anti-fade reagent (Invitrogen, Oregon, USA) and viewed by laser scanning confocal microscopy (LSM 510, Zeiss) for immunofluorescence.

Tissue sections were double labeled to co-localize H^+ -ATPase with Na^+ - K^+ -ATPase by using a modified protocol as previously described. Sections were deparaffinized and rinsed in 1xPBS, followed by blocking in 5% NGS solution (diluted in 1 x PBST). Sections were first incubated in anti- H^+ -ATPase mouse IgG in 5% NGS in 1 x PBST (1:500) overnight in a humidity chamber. Following three washes with 1xPBS, sections were incubated in AlexaFluor 568 Goat anti-Mouse IgG in 1 x PBS (1:2000) for 1 hour in a humidity chamber. Following three additional washes with 1 x PBS, sections were incubated with an anti- Na^+ / K^+ -ATPase mouse IgG in 5% NGS in 1 x PBST (1:500) overnight in a humidity chamber. Following three washes with 1 x PBS, sections were incubated with AlexaFluor 488 Goat anti-Mouse IgG in 1 x PBS (1:2000) for 1 hour at in a humidity chamber. Following three final washes with 1 x PBS, sections were mounted with Prolong Gold (Invitrogen, Oregon, USA) and viewed by laser scanning confocal microscopy (LSM 510, Zeiss) for immunoreactivity.

RESULTS

Gene Sequencing and Annotation

H⁺-ATPase

To obtain the full-length open reading frame (ORF) of brook trout H⁺-ATPase, three sets of primers were designed based on the H⁺-ATPase from rainbow trout, *Oncorhynchus mykiss* (GenBank Accession: AF140022.1, Table 1). Each set of primers yielded PCR products of ~800bp (TroutHAT-F1/R1), ~920bp (TroutHAT-F2/R2) and ~1100bp (TroutHAT-F3/R3). The ORF of H⁺-ATPase is 1375bp translating into 457 amino acids (Figure 6) also sequenced was 700bp of untranslated region. The brook trout H⁺-ATPase amino acid sequence was found to share a high degree of similarity with rainbow trout (87.5% identity; NP_001118069.1) and zebrafish (86.9% identity; NP_878299.1) when aligned using ClustalW (Figure 7).

NHE2

The partial ORF of brook trout, three sets of heterologous primers were designed against rainbow trout, *Oncorhynchus mykiss* NHE2 (GenBank accession: EF446605.2, Table 2). Each set of primers yielded PCR products of ~770bp (tNHE2-F2/B28), ~450 bp (tNHE2-F29/B36) and ~450bp (tNHE2-F37/B46). After assembly, the partial open reading frame is 1,485bp, which translates into 494 amino acids (Figure 8). The partial brook trout NHE2 amino acid sequence was found to share a high degree of similarity to rainbow trout (94.5%

identity; ABO32814.2) and longhorn sculpin (90.3% identity; AAD46576.2) when aligned using ClustalW (Figure 9).

NHE3

The full-length ORF of brook trout NHE3 was obtained utilizing four sets of heterologous primers designed against rainbow trout, *Oncorhynchus mykiss* NHE3 (GenBank Accession: NM_001130995.1, Table 3). Each set of primers yielded PCR products of ~350bp (TNHE3-F1/R1), ~930bp (TNHE3-F2/R2), ~750bp (TNHE3-F3/R3) and ~520bp (THNE3-F5/R5). The ORF of brook trout NHE3 contains 2,100bps, which translates into 699 amino acids (Figure 10). The Brook trout NHE3 amino acid sequences were found to share the most similarity to rainbow trout (92% identity; NP_001124467.1) and least similar to Osorezan dace (66.3% identity; BAB83083.1) when aligned using ClustalW (Figure 11).

Western Blot

Quantification of H⁺-ATPase expression in gill tissue

Use of the *anti-yeast H⁺-ATPase* antibody yielded a single immunoreactive band (approximately 65kDa) in brook trout gill tissue similar to the results reported by Perry et al. (2000) (Figure 12a). Changes in the relative protein expression of H⁺-ATPase were measured from fish (n = 6) collected from three elevations along Road Prong stream. The relative expression of H⁺-ATPase significantly (P<0.05) decreased from MRP fish to LRP fish (Figure 13). No significant change in H⁺-ATPase protein expression was observed between URP and MRP as well as URP and LRP.

Quantification of NHE2 expression in gill tissue

Use of the sculpin NHE2 antibody yielded a single immunoreactive band (approximately 85kDa) similar to the results reported by Catches et al. (2006) (Figure 12b). To date the relative expression of NHE2 has not been quantified for southern brook trout across an elevational gradient, although this will be analyzed at a later date.

Quantification of NHE3 expression in gill tissue

Use of the rainbow trout NHE3 antibody yielded two immunoreactive bands (approximately 95 and 97kDa) similar to the results reported by Ivanis et al. (2008) (Figure 12c). Density of the 95kDa band was recorded and analyzed for statistical significance. No significant change in the relative protein expression of NHE3 in the gills of southern brook trout was observed between all sites examined (URP, MRP and LRP) (Figure 13).

Relative expression of H^+ -ATPase and NHE3 between sites

Two-way analysis of variance determined that the relative expression of H^+ -ATPase and NHE3 did not significantly differ among sites (URP, MRP and LRP) (Figure 13).

Immunohistochemistry

Localization of H^+ -ATPase

Immunoreactivity of H^+ -ATPase was evident in the multiple epithelial cells within the interlamellar region and along the lamellae in the gills of southern brook trout. H^+ -ATPase staining was observed punctate along the apical membrane and within the sub-apical regions of all immunoreactive cells. Cell type was determined using dual-labeling

immunohistochemistry, where sections were stained for H⁺-ATPase and Na⁺/K⁺-ATPase immunoreactivity. Colocalization of H⁺-ATPase and Na⁺/K⁺-ATPase was observed in cells along the lamellae and within the interlamellar region, presumed to be MRCs (Figure 14B, C). There was no evidence of immunoreactivity in the negative controls incubated with normal goat serum and stained with a fluorescent secondary antibody within the cells and background (Figure 14A).

H⁺-ATPase expression was also examined in the gills of southern brook trout collected from different elevations along Road Prong stream. Basal expression of H⁺-ATPase was localized to the MRCs in all sections observed (Figures 15B, 16B, 17B). Although relative expression was not determined, the amount of immunoreactive cells appears to decrease with elevation from URP to LRP. Controls incubated with normal goat serum were negative with no observed background staining (Figures 15A, 16A, 17A).

Localization of NHE2

NHE2 immunoreactivity was observed in epithelial cells within the gills of southern brook trout. NHE2 staining was observed distinctly punctate along the sub-apical region of cells located along the lamellae and within the interlamellar region. Co-localization of NHE2 and Na⁺/K⁺-ATPase was observed in a large population of cells (presumed MRCs), where NHE2 appeared punctate closer to the apical region of the cell and Na⁺/K⁺-ATPase appeared diffuse throughout the cell (Figure 18B, C). However, NHE2 immunoreactivity was also detected in cells low in Na⁺/K⁺-ATPase expression. Negative controls incubated in normal goat serum and stained with fluorescent secondary antibodies showed no evidence of cellular immunoreactivity (Figure 18A).

NHE2 immunoreactivity was also examined in URP, MRP and LRP fish. NHE2 expression was localized to the MRCs in all sections observed (Figures 19B, 20B, 21B). NHE2 immunoreactivity was observed in few epithelial cells along the lamellae and within the interlamellar region of the filament in MRP fish. However, NHE2 immunoreactivity was observed in multiple epithelial cells in the gills of URP and LRP fish. Also, NHE2 immunoreactivity is only apparent in the MRCs located within the interlamellar region of the filament in LRP fish. Negative controls incubated in normal goat serum showed no evidence of cellular immunoreactivity (Figures 19A, 20A, 21B).

Localization of NHE3

NHE3 immunoreactivity was also present in gill epithelia cells in southern brook trout. NHE3 immunoreactivity appeared to be primarily localized to the apical crypt of epithelial cells located along the lamellae and within the interlamellar region of the filament. NHE3 appeared to be colocalized with Na^+/K^+ -ATPase, where Na^+/K^+ -ATPase staining was observed punctate and concentrated to the basolateral membranes of the presumed MRCs (Figure 23B, C). Negative controls incubated in normal goat serum and stained with a fluorescent secondary antibody were negative for immunoreactivity within all cells and the background (Figure 23A).

NHE3 immunoreactivity was also observed in southern brook trout collected from URP, MRP and LRP sites. NHE3 immunoreactivity was observed in the MRCs within all sections examined (Figures 24B, 25B, 26B). Although little NHE3 immunoreactivity was observed in URP fish, MRP fish appear to have a high density of immunoreactive cells. Also, it appears that NHE3 immunoreactivity is only in MRCs found within the interlamellar

region of the filament of LRP fish (Figure 26B). Controls incubated in normal goat serum were negative for cellular immunoreactivity and background staining (Figures 24A, 25A, 26A).

Colocalization of H⁺-ATPase and NHE2/3

NHE2 expression was colocalized to H⁺-ATPase containing cells along the lamellae and within the interlamellar regions of the filament (Figure 22B, C). NHE2 immunoreactivity appeared to be distinctly punctate around the sub-apical regions of the cell, where H⁺-ATPase appeared along the apical membrane and the sub-apical regions of the MRCs.

NHE3 expression was also colocalized to H⁺-ATPase containing cells along the lamellae, which were previously determined to be MRCs (Figure 26B, C). NHE3 immunoreactivity appears highly concentrated to the apical crypt of the MRCs, where H⁺-ATPase appears punctate along the apical membrane and the sub-apical regions of the cells. NHE2 and NHE3 immunofluorescence was not observed in sections where primary antibody was omitted (Figures 22A, 26A).

DISCUSSION

To date this is the first study to examine the physiological mechanisms governing acid-base regulation in southern Appalachian brook trout while experiencing stormflow events. It was first suggested by Krogh (1937) that freshwater fish take up NaCl from the environment in exchange for H^+ and HCO_3^- . Many studies have investigated the physiological mechanisms that fish utilize to regulate plasma osmolarity as well systemic pH. It has been widely accepted that freshwater fish tend to alter the relative expression of H^+ -ATPase in the gills when experiencing systemic acidosis (Perry et al., 2000; Yan et al., 2007). Although, recent evidence suggests that some freshwater fish species utilize NHE2 and NHE3 to excrete proton ions and regulated acid-base balance when exposed to acidic waters (Hirata et al., 2003; Ivanis et al., 2008; Furukawa et al., 2011). We hypothesized that southern brook trout utilize H^+ -ATPase, NHE2 and NHE3 expression in the gills when faced with acid-base perturbation. This study successfully cloned the open reading frame of H^+ -ATPase, NHE2 and NHE3 from the brook trout as well as determined protein localization and relative protein expression of each transporter in the gills of southern brook trout over an elevational gradient.

Sequence analysis of H^+ -ATPase, NHE2 and NHE3

Detection and analysis of H^+ -ATPase, NHE2 and NHE3 in the gills of the brook trout suggest that these ion-transporters are possible mechanisms by which pH homeostasis is maintained. Sequence analysis of southern brook trout H^+ -ATPase demonstrates the

conservation of this gene as it shares a high degree of similarity with that seen in rainbow trout (87.5% identical) and zebrafish (86.5% identical) (Figure 6). Perry et al. (2000) first displayed the conservancy of H⁺-ATPase in freshwater fish by aligning rainbow trout H⁺-ATPase with species representing all major organisms. This study reported that rainbow trout H⁺-ATPase shared a high degree of similarity from the invertebrate sea squirt to the mammal B-subunit, suggesting H⁺-ATPase is highly conserved across all organisms (Perry et al., 2000). The high degree of similarity of the H⁺-ATPase amino acid sequences across freshwater teleost species suggests that function may also be conserved. Due to the incredible conservation of this gene across all species, a monoclonal yeast *anti*-H⁺-ATPase antibody is available commercially to determine protein localization and expression which will be discussed in the next section.

As described previously, H⁺-ATPase and multiple NHE isoforms function in both Na⁺ uptake and H⁺ excretion in the gills of teleost fishes. Investigation into NHE isoform distribution and function in the freshwater teleost fishes by Yan et al. (2007) suggested that NHE2 and NHE3b transcripts are highly expressed in the gills of zebrafish in low-Na⁺ and acidotic conditions. It was also reported that NHE2 and NHE3 transcripts were expressed in the gills of hypercapnic rainbow trout (Ivanis et al., 2008). More recently, NHE isoforms (NHE2) are found to contain multiple subtypes possibly resulting from the teleost genome duplication event (Edwards et al., 2010). Although not investigated in this study, we speculate that southern brook trout also possess multiple NHE isoform subtypes and requires further study. In this study, we determined that NHE2 and NHE3 transcripts are expressed in the gills of brook trout. Alignment of the partial NHE2 amino acid sequence demonstrated a high degree of conservancy when aligned against rainbow trout NHE2 (94.5% identity;

ABO32814.2) and longhorn sculpin (90.3% identity; AAD46576.2). Also, alignment of the brook trout NHE3 amino acid sequence demonstrated 92% identity with rainbow trout NHE3 (ABO32815.2) and 66.3% identity with the Osorezan dace (BAB83083.1). Most variation in sequence similarity is observed near the C-terminus carboxyl tail, which as previously mentioned plays a role in function and regulation of multiple NHE isoforms (Orlowski and Grinstein, 2004). It is possible that as amino acid sequence is highly conserved, function would also be conserved throughout teleost fishes. Due to limited genetic data characterizing NHE2 and NHE3 in salmonid species, further investigation is required. The conserved nature of NHE2 and NHE3 in teleost fishes led to the availability of homologous polyclonal antibodies to determine the relative protein expression and localization of NHE2 and NHE3 in the gills of southern brook trout which will further be discussed in the following section.

Localization of H⁺-ATPase, NHE2 and NHE3 in gill MRCs

The current working model for ion transport in freshwater adapted fish gills suggests that H⁺-ATPase, NHE2 and NHE3 are co-localized to the apical membrane of PNA⁻ cells (Evans, 2010; Figure 2). The presence of both ion-transporters in the gills was confirmed via western blot, where membranes were probed with a primary antibody with an affinity to bind H⁺-ATPase (65kDa; Figure 12A), NHE2 (95kDa; Figure 12B) or NHE3 (95kDa; Figure 12C) respectively. Identification of these ion-transporter proteins within the gills suggests that the respective transcripts are translated in response to acid-base stimuli and the protein is functional in the cell.

By confirming the presence of H⁺-ATPase in the gills of brook trout by probing with a homologous yeast *anti*-H⁺-ATPase antibody allows for further investigation of protein

expression patterns via quantitative analysis of western blots. Early localization studies report that H⁺-ATPase is generally found in the apical and sub-apical endosomes of the MRCs and PVCs (Lin et al., 1994; Sullivan et al., 1995). These studies suggested that apical H⁺-ATPase is electrogenically coupled to an ENaC, and facilitates Na⁺ absorption by active proton excretion causing a shift in charge within the intercellular fluid. In agreement with these studies, our results indicate that H⁺-ATPase is localized to the apical and sub-apical membrane of gill epithelia cells (Figure 14B, C). Using dual labeling immunohistochemical techniques, we were able to co-localize H⁺-ATPase expression with Na⁺/K⁺-ATPase expression in cells along the lamellae and in a few cells within the interlamellar region. As previously mentioned MRCs are rich in Na⁺/K⁺-ATPase activity and were used to detect the location of MRCs in the gill epithelia (Evans et al., 2005). Therefore, we can confirm that H⁺-ATPase is localized to the apical regions of the MRCs. Also, we observed H⁺-ATPase expression in the sub-apical region of the cell suggesting that these proteins are stored within sub-apical endosomes. This would be advantageous for southern brook trout as they do face random stream acidification events and stored H⁺-ATPase would be readily trafficked to the apical membrane. The localization of H⁺-ATPase in the apical membrane suggests it plays a role in the active excretion of protons when faced with an acid-base perturbation.

Multiple NHE isoforms have been localized to the gills of agnathans (Edwards et al., 2001), elasmobranchs (Edwards et al., 2002; Claiborne et al., 2008) and multiple freshwater and seawater teleost fishes (Hirata et al., 2003; Edwards et al., 2005; Yan et al., 2007; Ivanis et al., 2008; Furukawa et al., 2011; Lin et al., 2012). NHE2 expression was localized to the apical membrane and sup-apical regions of MRCs within the gills of tilapia (Wilson et al., 2000a), killifish (Edwards et al., 2005) and longhorn sculpin (Catches et al., 2006). Similar to

NHE2, NHE3 was localized to gill MRCs in the Osorezan dace (Hirata et al., 2003), zebrafish (Yan et al., 2007), rainbow trout (Edwards et al., 1999; Ivanis et al., 2008), the Mozambique tilapia (Furukawa et al., 2011) and most recently the medaka (*Oryzias latipes*). In this study, we confirmed the presence of the NHE2 and NHE3 exchanger protein in the gills of southern brook trout via western blot analysis resulting in an immunoreactive band at ~95kDa (Figure 12B, C). Previous studies using heterologous NHE2 antibodies and the A94-APS antibody yielded an immunoreactive band of a similar size (~85kDa) in the the killifish (Edwards et al., 2005) and the longhorn sculpin (Catches et al., 2006). Use of the trout *anti-NHE3* polyclonal antibody yielded two immunoreactive bands at 95kDa and 98kDa in the gills of rainbow trout which is suggested to be NHE3a and NHE3b respectively (Ivanis et al., 2008). They suggest that the polyclonal antibody is not specific to binding either isoform NHE3a or NHE3b, therefore the second immunoreactive band seen in our blots is possibly NHE3b. Further investigations will be utilized to test this hypothesis. In order to quantify the relative expression of either NHE3 isoform within the gills of southern brook trout, a more selective antibody must be used. By confirming the affinity of both sculpin *anti-NHE2* and trout *anti-NHE3*, we can use these antibodies to observe the localization and determine the relative expression of these exchanger proteins in the gills of southern brook trout.

This study proved successful in demonstrating the use of heterologous antibodies to localize NHE2 protein expression in the gill epithelium of southern brook trout. Previous studies have localized NHE2 expression to the apical membrane of the MRCs in tilapia (Wilson et al., 2000a), longhorn sculpin (Catches et al., 2006), rainbow trout (Ivanis et al., 2008) and multiple elasmobranch species (Edwards et al., 2002; Claiborne et al., 2008). In agreement with these studies, NHE2 immunoreactivity was observed in a punctate staining

pattern around the apical and sub-apical regions of gill epithelia cells of southern brook trout (Figure 18B,C). The distinct punctuate staining of NHE2 proteins in the sub-apical regions of these cells suggests that NHE2 is stored in sub-apical endosomes, similar to that of H⁺-ATPase. Colocalization of NHE2 in Na⁺/K⁺-ATPase immunoreactive MRCs suggests that NHE2 possibly plays a functional role in ion-transport or acid-base balance in gill epithelia of southern brook trout (Figure 18B,C). By storing NHE2 in sub-apical endosomes within gill MRCs, southern brook trout would not need to expend energy by increasing the relative expression of NHE2, but rather trafficked and incorporate NHE2 proteins into the apical membrane when faced with acid-base perturbation.

We have also determined that NHE3 is localized specifically to the apical membrane of Na⁺/K⁺-ATPase rich cells, which as earlier described are presumed MRCs (Figure 23). Previous studies using the same trout anti-NHE3 antibody localized NHE3 expression to Na⁺/K⁺-ATPase immunoreactive PNA⁺ MRCs (Ivanis et al., 2008). Although we did not determine the identification of either α -MRCs (PNA⁻) or β -MRCs (PNA⁺) via PNA staining, we can say that NHE3 expression was confined to the MRCs found along the lamellae and within the interlamellar region of the filament. Apical localization of NHE3 within MRCs suggests that it plays a role in Na⁺ absorption and NH₄⁺/H⁺ excretion via passive transport from the intercellular fluid into the external environment. As it would seem that the low ionic concentration of the environment would not be sufficient to facilitate NHE activity, it is suggested that increased basolateral Na⁺/K⁺-ATPase activity maintains a low intracellular Na⁺ concentration, thus creating a favorable inward gradient for Na⁺ absorption and H⁺ excretion via NHE (Hirata et al., 2003).

In order to increase net acid excretion from the gills, we speculate that southern brook trout utilize all three of these acid excreting ion-transporters within gill epithelial cells. Through dual-labeling immunohistochemistry, H⁺-ATPase protein expression was colocalized with NHE2 protein immunoreactive cells (Figure 22B, C) and NHE3 immunoreactive cells (Figure 27B, C). This provides evidence that H⁺-ATPase, NHE2 and NHE3 are localized to gill MRCs along the lamellae and within the interlamellar region of the filament. By expression H⁺-ATPase, NHE2 and NHE3 in the apical membrane of MRCs, southern brook trout would be able to increase net acid excretion when faced with acid-base perturbation. This data agrees with the previous ion-transport models suggested by Perry and Gilmour (2006) and Evans (2010) (Figure 2).

Utilization of H⁺-ATPase, NHE2 and NHE3 in gill epithelia

The specific aim of this study was to determine changes in the relative protein expression of H⁺-ATPase, NHE2 and NHE3 in gill epithelia of southern brook trout. As mentioned previously, stormflow events in the GRSM cause an acute drop in stream pH which then causes physiological stress in southern brook trout (Deyton et al., 2009; Neff et al., 2009). We hypothesized that these drops in stream pH induce acidosis within these fish which then would alter the relative concentrations of acid secreting ion-transporters in gill epithelia (H⁺-ATPase, NHE2 and NHE3). Western blot analysis determined that relative H⁺-ATPase protein expression slightly increased from the URP to the MRP trout and significantly (P<0.05) decreased in MRP trout to the LRP trout and that there was no significant difference between URP and MRP fish as well as URP and LRP fish. Due to the difference in location and size of the water shed associated with each collection site, it is

possible that the MRP trout experience more acidic and ion rich water than URP fish. This would require the animal to increase H^+ -ATPase protein expression to combat any decrease in stream pH at the MRP site rather than UPR. Also, these findings suggest that stream ANC and pH are restored as the stream flows from the MRP to the LRP site, causing a significant decrease in gill H^+ -ATPase protein expression. As stream acidification is caused and buffered by multiple complex biogeographical processes, it is difficult to pinpoint the main cause associated with significant decreases in H^+ -ATPase protein expression between MRP and LRP fish. This could possibly be associated with a change in geology, flora or soil quality between these sites and amongst their watersheds. Although stream chemistry data at each site was not recorded at the time of collection, our results follow a trend associated with changes in stream pH seen by Cook et al. (1994) and Deyton et al. (2009) where stream ANC and pH is relatively low at higher elevations and is rescued as stream elevation decreases. It is interesting that H^+ -ATPase protein expression in the URP and the LRP fish did not significantly differ although there was an obvious decrease, which in part could be accounted for by a relatively small sample size ($n = 6$) at each site. This data suggests that southern brook trout do significantly alter H^+ -ATPase protein expression in accordance to elevation during a stormflow event. Taken together, by utilizing H^+ -ATPase, southern brook trout use ATP to facilitate active branchial proton excretion via H^+ -ATPase, resulting in metabolic demand. Although this study did not directly investigate this, we plan to investigate this in future studies.

Surprisingly the relative protein expression of NHE3 in the gills did not significantly change over the elevation gradient (Figure 13) which can also be seen in stained gill sections from URP (Figure 24), MRP (Figure 25) and LRP (Figure 26) fish. These results suggest that

NHE3 may not play a role in acid excretion but possibly Na^+ uptake linked to ammonium excretion in the gills of southern brook trout. Similar expression patterns have been reported in rainbow trout, where NHE3 is assumed to play a role in the increase in net Na^+ absorption rather than acid secretion (Ivanis et al., 2008). On the contrary, NHE3 protein expression is upregulated in acidotic Osorezan dace (Hirata et al., 2003), tilapia (Furukawa et al., 2011) and medaka (Lin et al., 2012) which compared to rainbow trout (Perry et al., 2000; Ivanis et al., 2008) and finally brook trout suggests freshwater fish display different mechanisms in regulating acid-base balance by the gills and require further investigation. Interestingly, brook trout NHE3 shares a low degree of similarity with dace NHE3 although they live in similar environmental conditions and would possibly utilize NHE3 in a similar fashion. However, the high degree of similarity shared between rainbow trout NHE3 and brook trout NHE3 suggests that this transporter protein is homologous and may have diverged along with the colonization of freshwater environs by early salmonid ancestors. To date, the relative protein expression of NHE2 in the gills of southern brook trout at each site has not been examined fully. In order to determine whether southern brook trout utilize NHE2 in the gills in accordance to elevation, further investigation must also be considered. Taken together, our results indicate that southern brook trout possess epithelial transport mechanisms that would respond to a systemic acidosis resulting from stream acidification.

Pitfalls

Although this study included multiple positive results, there were a few pitfalls that made interpretation of our results difficult. To start, at the time of animal collection water chemistry data was not recorded. Also, the portable pH meter used could not be calibrated at

the time of collection and in turn could not produce accurate blood pH readings; therefore this data was not recorded. Without these observations, we were unable to determine whether or not the stream was not acidic following a similar trend of stream acidification and we were not able to determine whether or not the trout were experiencing acidosis. Therefore, when interpreting our protein expression data at each site, we could only correlate our findings with the stormflow event that was currently happening and not with stream acidification. The current stream chemistry data available for Road Prong stream has only been collected at one site and not along an elevation gradient. Also, we could not confirm that these trout were experiencing acidosis due to stream acidification. Thus, stream chemistry data and blood pH of must be recorded during the next collection of animals to confirm that the fish are acidotic and that it is caused by a drop in stream pH.

Conclusions

It is imperative for all fishes to maintain a homeostatic systemic pH and thus the physiological mechanisms that govern this vary greatly between freshwater acclimated fish. As the headwater streams that southern brook trout inhabit experience regular acidification events, these fish must implement mechanisms that allow for survival during low pH conditions. As seen in other freshwater fishes, namely the rainbow trout, H^+ -ATPase, NHE2 and NHE3 are acid secreting ion-transporters that work together to maintain systemic pH as well as plasma osmolarity. We have demonstrated evidence for the presence of H^+ -ATPase, NHE2 and NHE3 in the gills of southern brook trout, *Salvelinus fontinalis* as well as determined localization and differential expression of these ion-transporters along an elevational gradient. We can confirm that southern brook trout have the ability to alter the

relative protein expression of H⁺-ATPase and not NHE3. Identification of these mechanisms allows us to better understand the physiological mechanisms possessed and utilized by southern brook trout to inhabit acidic environments as well as survive acute drops in stream pH.

Future studies

This study succeeded in laying the foundation for future studies investigating the physiological mechanisms governing the regulation of acid-base balance in southern brook trout. Although H⁺-ATPase, NHE2 and NHE3 were discovered, there is no further molecular or protein biochemical data available for southern brook trout, therefore identification of other acid-base excretion proteins (Na⁺/HCO₃⁻ cotransporter, Cl⁻/HCO₃⁻ exchanger and Carbonic anhydrase) will be investigated in the future. We plan to analyze the relative expression of these ion-transporters in the gills and kidneys of southern brook trout via *in vivo* wet lab experiments. By inducing hypercapnic acidosis we can get a better idea of how these fish respond to low pH environments, such as acute stream acidification. Also, we plan to measure and record cortisol levels of hypercapnic trout to determine whether these fish are in fact experiencing physiological stress during acid-base perturbation. With this, we will be able to create and propose new management strategies associated with the preservation of this species in the Great Smoky Mountains National Park.

Fresh Water

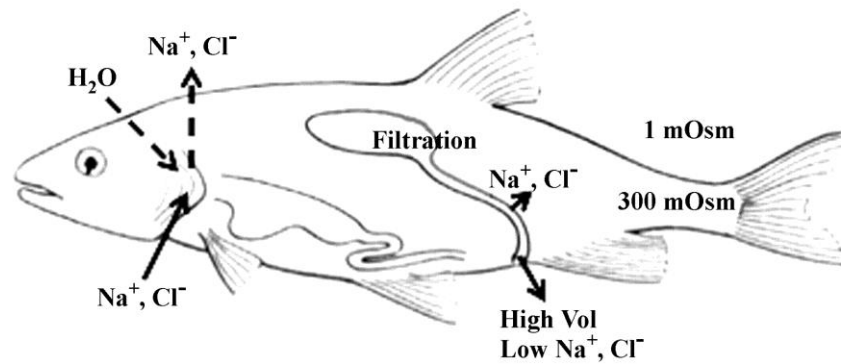

Seawater

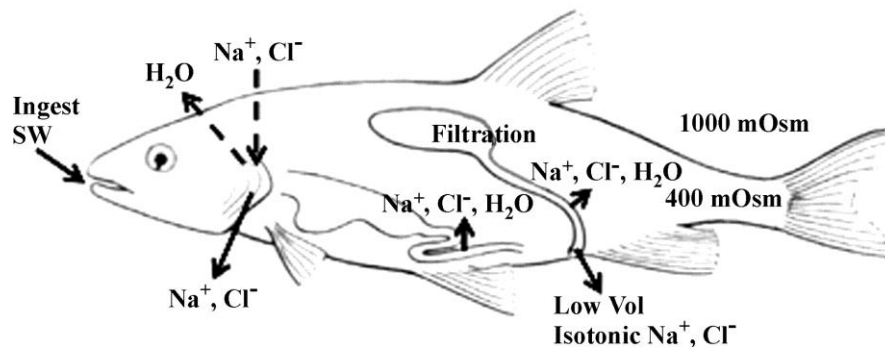

Figure 1. Osmoregulation in freshwater and seawater adapted fish. The internal osmolarity of freshwater adapted fish is much greater than that of the environment. This causes the fish to passively absorb water while simultaneously losing Na⁺ and Cl⁻ ions to the environment. This causes that fish to produce copious amounts of hypotonic urine as well as actively up-taking Na⁺ and Cl⁻ through gill epithelia as well as through ingestion. As seen in seawater adapted fish whose internal osmolarity is much lower than that of the environment are passively absorbing Na⁺ and Cl⁻ from the environment, which forces them to actively excrete Na⁺ and Cl⁻ ions. Excretion of Na⁺ and Cl⁻ is found to happen through gill epithelia (Evans, 2008).

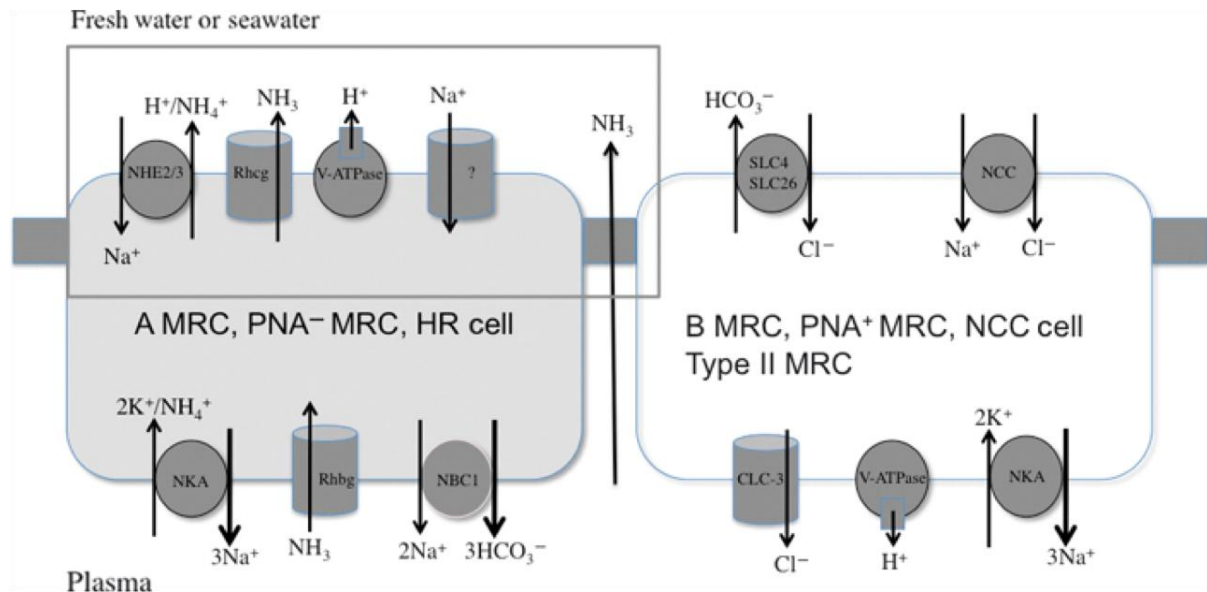

Figure 2. Current working model of ion regulation in fish gill epithelia. The α -MRC (PNA⁻) facilitates acid excretion and Na⁺ uptake via apically localized H⁺-ATPase coupled to an epithelial Na⁺ channel and NHE2/3. The β -MRC (PNA⁺) facilitates both NaCl uptake and base secretion via apically localized NCC and CBE (Evidence for these proteins can be found in Evans, 2010).

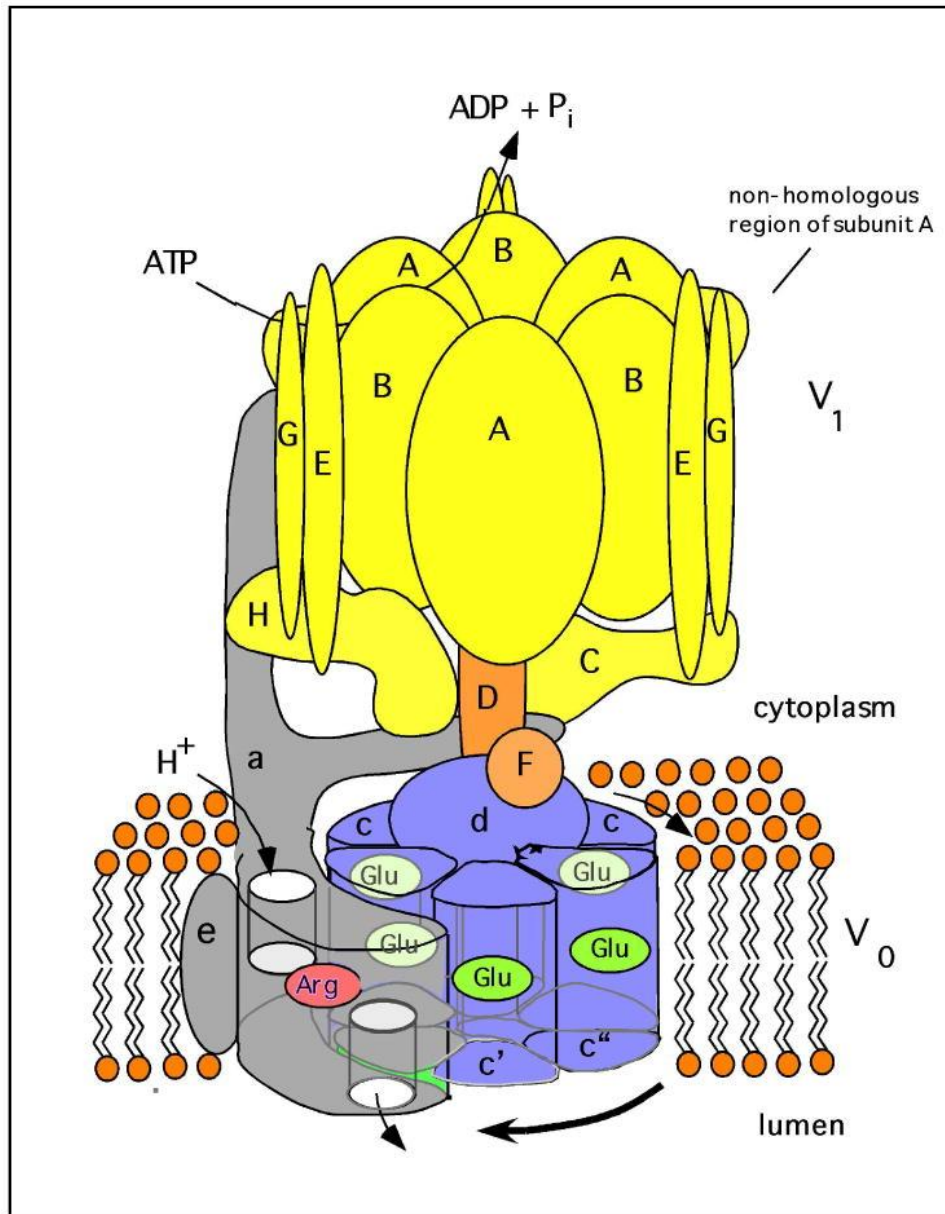

Figure 3. Structure and mechanism of H⁺-ATPase. The V₁ domain consists of eight subunits: A, B, C, D, E, F, G and H. The V₁ domain is responsible for ATP binding and hydrolysis which results in a 120° rotation. The V₀ domain consists of six subunits: a, c, c', c'', d and e. This functional domain moves protons through the lipid bi-layer membrane to the lumen due to the rotation of the proteolipid ring constructed of c subunits. The proteolipid ring is rotated by the central stalk of the V₁ domain during ATP hydrolysis (Toei et al., 2010).

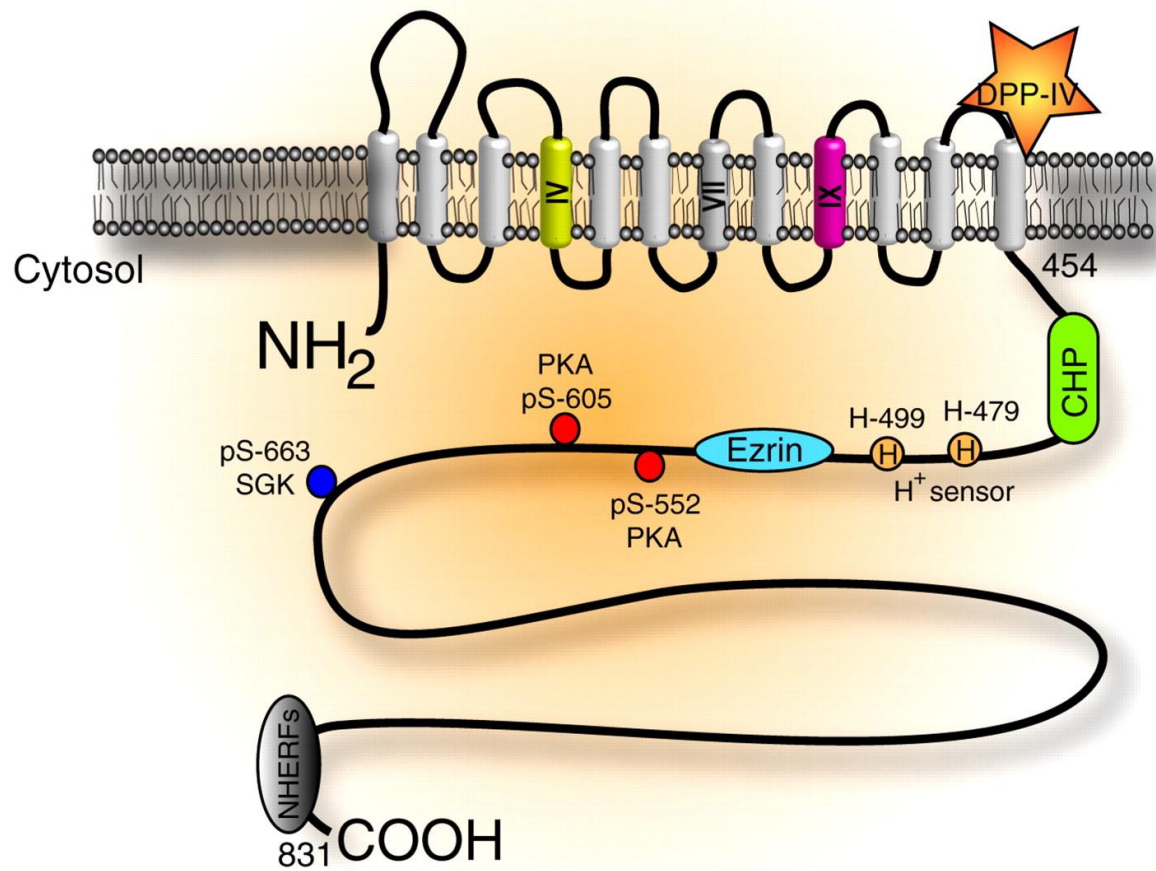

Figure 4. Structure of Na⁺/H⁺ exchanger isoform-3. NHE3 is a trans-membrane protein with 11 membrane spanning domains. The c-terminus tail is located within the cytoplasm and contains multiple H⁺ sensors as well as other regulatory elements. Domain IV is the site for Na⁺/H⁺ exchange. (Alexander and Grinstein, 2009).

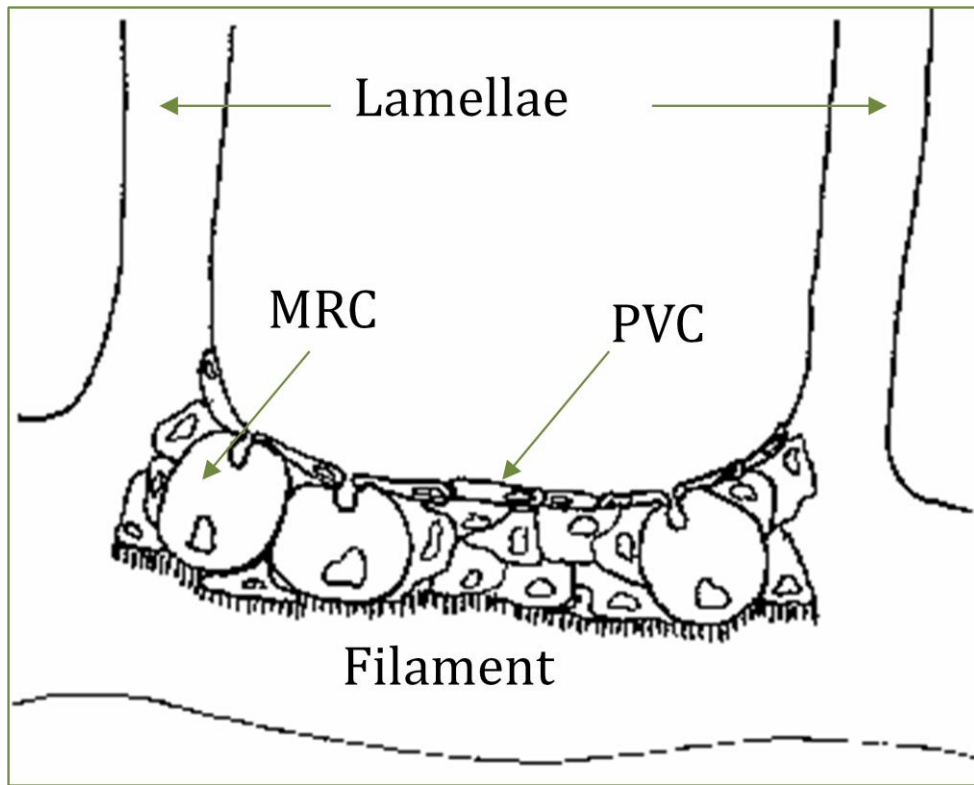

Figure 5. Model of fish gill epithelia. Numerous lamellae protrude from the gill filament. Pavement cells (PVCs) are seen on the apical epithelia of the interlamellar space. Mitochondria-rich cells (MRCs) are located between the apical membrane of the interlamellar space and PVCs. PVCs are more numerous and less dense than MRCs (Edwards, 2000).

Table 1. Primer sequences used to clone H⁺-ATPase.

| Primer name | Position | Product size | Sequence |
|-------------|----------|--------------|--------------------------------|
| TroutHAT-F1 | 155 | 888 | 5' GCCCCTGGTGATTCTGGATAATG 3' |
| TroutHAT-R1 | 1042 | | 5' ATCTGAGTGATGGAGCCGTTCC 3' |
| TroutHAT-F2 | 555 | 919 | 5' ATCCCCATCTTTTCTGCCGC 3' |
| TroutHAT-R2 | 1473 | | 5' TCCGCTTCAGCATTCTTTGG 3' |
| TroutHAT-F3 | 1105 | 1145 | 5' TCACTGAGGGACAGGTCTATGTGG 3' |
| TroutHAT-R3 | 2249 | | 5' AACAGAGATGATTCGGCAAACG 3' |

```

1          F1 →
F2 1  G C C C T G G T G A T T C T G G A T A A T C G A A G T T T C C C A G G T A T G C A G A G A T T G T C A C C T G A C T T T G C C T G A T G G C A C C A G G A G A G T G C C A G G T G C T G G A G 100
1  P L V I L D N V K F P R Y A E I V H L T L P D G T R R S G Q V L E 33
101  G T G A T T G G C A C C A A G G G C T G C G T A C A G G T G T T G A G G G G A C A T C T G G T A T T G A C G C C A A G A A G A C G G C C T G T G A G T T C A C C G G T G A C A T C C T G C C A C A C 200
F2 34  V I G T K G C R T G V E G T S G I D A K K T A C E F T G D I L R T P 67
201  C T G T G T G A G G A C A T G T G G G A C G T G T T T C A A T G G C T C A G C A A G C C C A T T G A C C T G G C C C A C T G T G C T G G C T G A A G A C T A C T T G G A C A T C A T G G G 300
F2 68  V S E D M L G R V F N G S G K P I D R G P T V L A E D Y L D I M G 100
301  C C A G C C C A T C A A C C C T C A G T G C C G T A T C T A C C C T G A A G A G A T G A C C A G C C G G T A T C T C T G C C A T C G A T G G G A T G A A C A G C A T C G C C C G A G G T C A G A A G 400
F2 101 Q P I N P Q C R I Y P E E M I Q T G I S A I D G M N S I A R G Q K 133
401  A T C C C A T C T T C T C T G C A G C C G C C T G C C C C A C A A C G A G A T T G C T G C C C A G A T T T G C T G A G C T G C C T G G T G A A G A A A T C C A A G G A T G T G A T G G A C T 500
F2 134 I P I F S A A G L P H N E I A A Q I C R Q A G L V K K S K D V M D Y 167
501  A C A G C C A T G A T A A C T T T G C C A T T G T C T T T G C T G C C A T G G G G T G A A C A T G G A A A C T G C T C G C T T C T T C A A G T C G G A C T T T G A G G A G A A T G G A T C C A T G C A 600
F2 168 S D D N F A I V F A A M G V N M E T A R F F K S D F E E N G S M D 200
601  C A A T G T T T G C C T G T T C T T G A A C T A G C C A A C G A C C C C A C T A T T G A G C G C A T C A T C A C C C C T G C C T G G C T G T G A C C T C A G T C A G T A C T G G C C T A C C A G 700
F2 201 N V C L F L N L A N D P T I E R I I T P R L A L T S A E Y L A Y Q 233
701  T G T G A A G A C A T G T C C T G G T C A T C C T G A C T G A C A T G A C T F C T A C G C C G A A G C T C T G A G A G A G G T G T C A G C T G C C A G A G A G G A A G T C C T G G C C G T C G T G 800
F2 234 C E K H V L V I L T D M S S Y A E A L R E V S A A R E E V P G R R G 267
801  G T T T T C C C G G T T A C A T G T A C A C G G A T C T G G C T A C C A T C T A C G A G C G T G C C G G C A G A G T G G A G G G C A G G A A C C G G T C C A T C A C T C A G A T A C C C A T C C T C A C 900
F2 268 F P G Y M Y T D L A T I Y E R A C R V E G R N G S I T Q I P I L T 300
901  C A T G C C C A A C A G A T A T A C C C A T C C C A T T C C T G A T C T C A C T G G T A C A T C A C T G A G G A C A G A G T C T A T C T G G A C A G A C A G T G C A C A A C A G A C A G A T C 1000
F2 301 M P N D D I T H P I P D L T G Y I T E G Q V Y V D R Q L H N R Q I 333
1001 T A C C C A C C C A T C A A T G T G T G C C C T C T C T G T C T C G A T T G A T G A A G T C T G C C A T C G G T G A A G A A T G A C C C G T A A A G A C C A T G C T G A T G T C C A A T C A G T 1100
F2 334 Y P P I N V L P S L S R L M K S A I G E G M T R K D H A D V S N Q L 367
1101 T G T A T G C C T G C T A T G C C A T T G G T A A G G A C T G C A G G C C A T G A A A G C C G T G G T C G G A G A G A G G C C C T C A C C T C C G A T G A T C T G C T A C C T G G A G T T T C T 1200
F2 368 Y A C Y A I G K D V Q A M K A V V G E E A L T S D D L L Y L E F L 400
1201 G C A G A A G T T T G A G A A A C T T C A T C G C T C A G G C C C T T A T G A C A A C A G G A C T G T G T A T G A G A C C C T G G A C A T T G C T G C C A G C T G C T C C G A A T C T T C C C C 1300
F2 401 Q K F E K N F I A Q G P Y D N R T V Y E T L D I G W Q L L R I F P 433
1301 A A G A A A T G C T G A A G C G G A T T C C C C A G A C A C C C T G G C T G A G T T C A C C C A G G G A C T G C G A C T C G T C A C T G A 1375
F2 434 K E M L K R I P Q S T L A E F Y P R E S A A R H * 457

```

Figure 6. Full-length nucleotide sequence for H⁺-ATPase. The open reading frame of H⁺-ATPase in *Salvelinus fontinalis* consists of 1375bp. TroutHAT-F1/R1 primers are highlighted in red, TroutHAT-F2/R2 primers are highlighted in blue, and TroutHAT-F3/R3 primer sequences are highlighted in green. Translated amino acid sequence is positioned under the ORF.

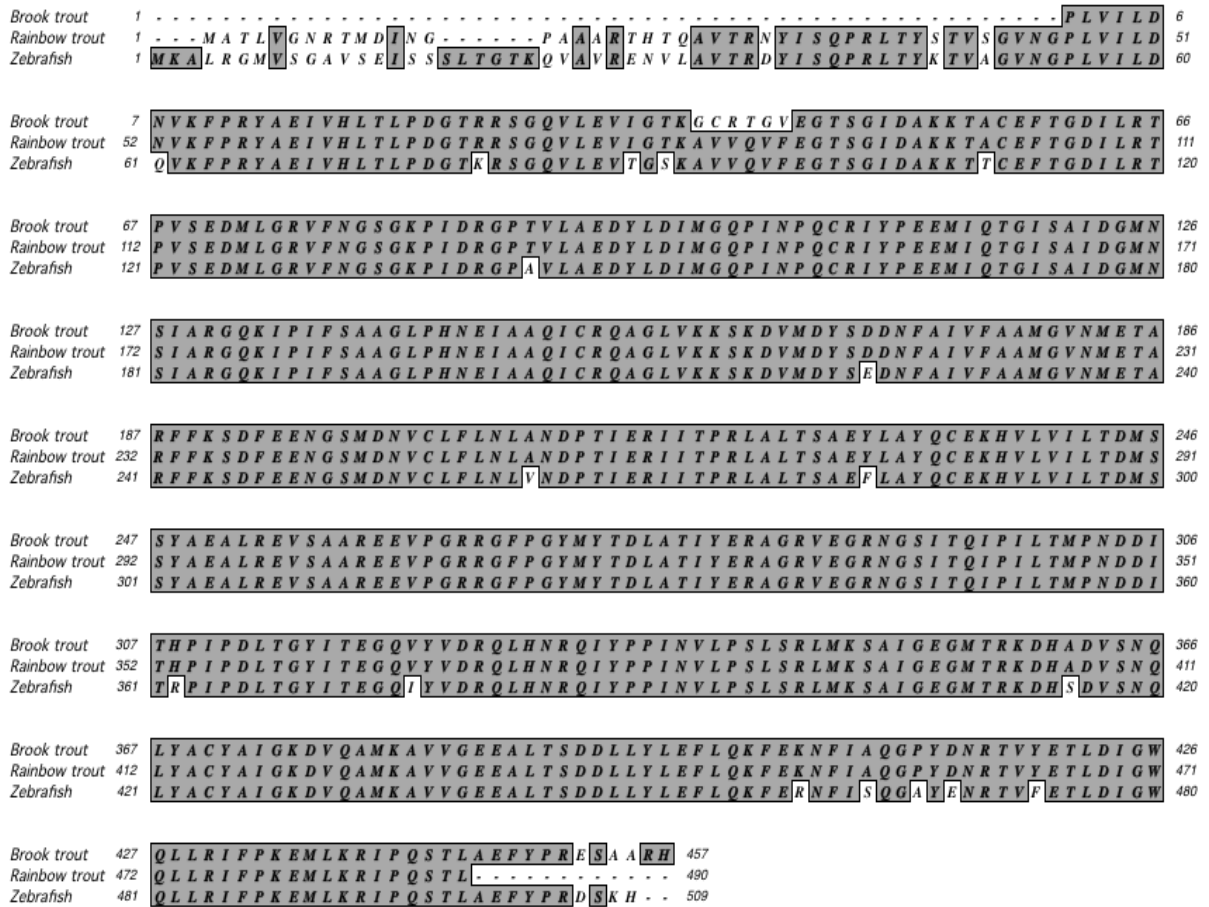

Figure 7. Multiple sequence alignment of H⁺-ATPase in teleost fishes. Brook trout H⁺-ATPase is found to be similar (87.5% identity) to rainbow trout H⁺-ATPase, *Oncorhynchus mykiss* (NP_001118069.1) and similar (86.9% identity) to zebrafish, *Danio rerio* H⁺-ATPase (NP_878299.1). Amino acids within grey blocks are identical.

Table 2. Primer sequences used to clone NHE2.

| | Position | Product Size | Sequence |
|------------|----------|--------------|---------------------------------|
| TNHE2-F2 | 91 | 779 | 5' TACACGGAGATTCCACCCAAACCC 3' |
| TNHE3-RB28 | 869 | | 5' AAGATGACACCAAAGCCCATACC 3' |
| TNHE3-F29 | 721 | 450 | 5' TGCCTGTTCAACGATGCTGTC 3' |
| TNHE3-RB36 | 1178 | | 5' ATGATGTAGCCCCAGTTCCACTCG 3' |
| TNHE3-F37 | 1134 | 443 | 5' GGTCACCATAACAACAGAACACGAG 3' |
| TNHE3-RB46 | 1576 | | 5' TGTCCTTCCAGTAGTAGTGGCTCC 3' |

→ **F2**
1 TTACACGGAGATTCCACCCAAACCCGTTGGTTCCGTGACCGTCTACCCCTGTCAAGCCAGCGGGGCTCCACAAGCGTTCCCGACGCGGAGAATCG 100
F2 1 Y T E I P P K P P G S V T V L P P V K P A G A P Q A F P D A E N S 33
101 AATCTCCCGGTCTTACAATGGATTATCCCGTATACAGGAGCCGTTTGGAGTACAGCTTTGGGTGCTGCTCGCGTCATTCGCCAAGATTGGTTCCATG 200
F2 34 N L P V F T M D Y P R I Q E P F E V T L W V L L A S F A K I G F H V 67
201 TATACCACAAGATTACCTTCTGGTCCCAGAGTCACTGCTCCTGATCAGTATTGGGCTGATCGTAGGGGCCATCATGCACTCTGTCCACGAGGAGCCCC 300
F2 68 Y H K I T F W V P E S C L L I S I G L I V G A I M H S V H E E P P 100
301 TGCTGTCTCAGCTACAACGCTTCTTCTCTCTCTGCTGCCCTCCCATCGTACTGGAGTCTGGATACTTTATGCCACGCGACCGTCTCTCAGAACCTG 400
F2 101 A V L S Y N V F F L F M L P P I V L E S G Y F M P T R P F F E N V 133
401 GGAACGGTCTTTGGTTTGGCGTGGGCACCCCTGGAACAGCATTGGGATAGGATGCTCTCTATCGGTGTCTCAGATCGAGCGCTTTGAGTGC 500
F2 134 G T V L W F A V V G T L W N S I G I G M S L Y A V C Q I E A F E V Q 167
501 AGGACATTAACCTTACAGGAGAATCCTGTTTGGTGCATCATCTCAGCTGTGGACCAAGTGGCCGTGCTCAGCGTGTTCGAGGATGCTCTGTCAACGA 600
F2 168 D I N L Q E N M L F A A I I S A V D P V A V L S V F E D V S V N E 200
601 GCAGCTTACATCGTGGTGTGGAGAGTGCCTGTCAACGATGCTGCTACTGTGGTGTCTACAACATGTTAACTTCGTAGCAGAAATGCCGATGGT 700
F2 201 Q L Y I V V F G E C L F N D A V T V V L Y N M F N F V A E M P M V 233
701 GAGCCGTGATGATTTCTGGCGTGGCTAGGTTCTTCTGCTGGTGGCCCTGGGCGGATGGCTTTGGTGTCTCTTTGGCTTGTAGCCTCTTACCA 800
F2 234 E P V D V F L G V A R F F V V G L G G M G F G V I F G F V A S F T T 267
801 CACGTTTACCCTCAACGTCAGGAGATAGAACCCTCTTTATCTTCATGTACAGCTACCTGGCCTACCTGCTAGCAGAGCTGTTCTCCATCTCCAGCAT 900
F2 268 R F T S N V R E I E P L F I F M Y S Y L A Y L V A E L F S I S S I 300
901 CATGGCATTGTGACCTGTGCCCTGACCATGAAGTACTATGTGGAGGAGAATGTCTCCACGCGTCTGCACCACTATCCGCCATGTGGTCAAGATGTT 1000
F2 301 M A I V T C A L T M K Y Y V E E N V S Q R S C T T I R H V V K M L 333
1001 GGCACCATCTCAGAAACCTCATCTTCTTCTTCTGGCGTGGTCCACATACACAGAACCGAGCGCACTGGCGCTATATCATTTTCACGCTGCTGT 1100
F2 334 G T I S E T L I F F F L G V V T I T T E H E R N W G Y I M F T L L L 367
1101 TGGCCTTAGTGTGGAGAGCGCTGGGTGCTGCTGACCCAGATCATTAAACCTTTCCGCACCATCCCCTTCAACTTCAAGGACCAGTTTATTCTGG 1200
F2 368 A L V W R G L G V L V L T Q I I N P F R T I P F N F K D Q F I L G 400
1201 TTATGGTGCCTGCGAGGGCAATCTCCTTTGCCCTGGTCTTACCCTGGCAGACAGCATCGGCCGAAGAACTCTTTGTACCACCACCATCTGTATG 1300
F2 401 Y G G L R G A I S F A L V F T L P D S I G R K K L F V T T T I C M 433
1301 ATCATGTTACAGTCTTATCCAGGAATCAGCATACGGCCCTGTATCGAGTTCATCAACGTCGCCGAGAACCAACCGCAACCTGGAGACCATCAACGTAG 1400
F2 434 I M F T V F I Q G I S I R P L I E F I N V R R T N R N L E T I N V E 467
1401 AGATCCACTCCAGGCTCATAGAGCACACCATCTCTGGGTAGAGGACCTCTGTGGCCACTGGAGCCACTACTACTGGAAGGACAA 1485
F2 468 I H S R L I E H T I S G V E D L C G Q W S H Y Y W K D 494

Figure 8. Partial open reading frame of brook trout NHE2. The open reading frame of NHE2 in *S. fontinalis* consists of 1485bp (494 amino acids). TNHE2-F2/RB28 primers are highlighted in red, TNHE2-F29/RB36 primers are highlighted in blue, and TNHE2-F37/RB46 primer sequences are highlighted in green. Translated amino acid sequence is positioned under the ORF.

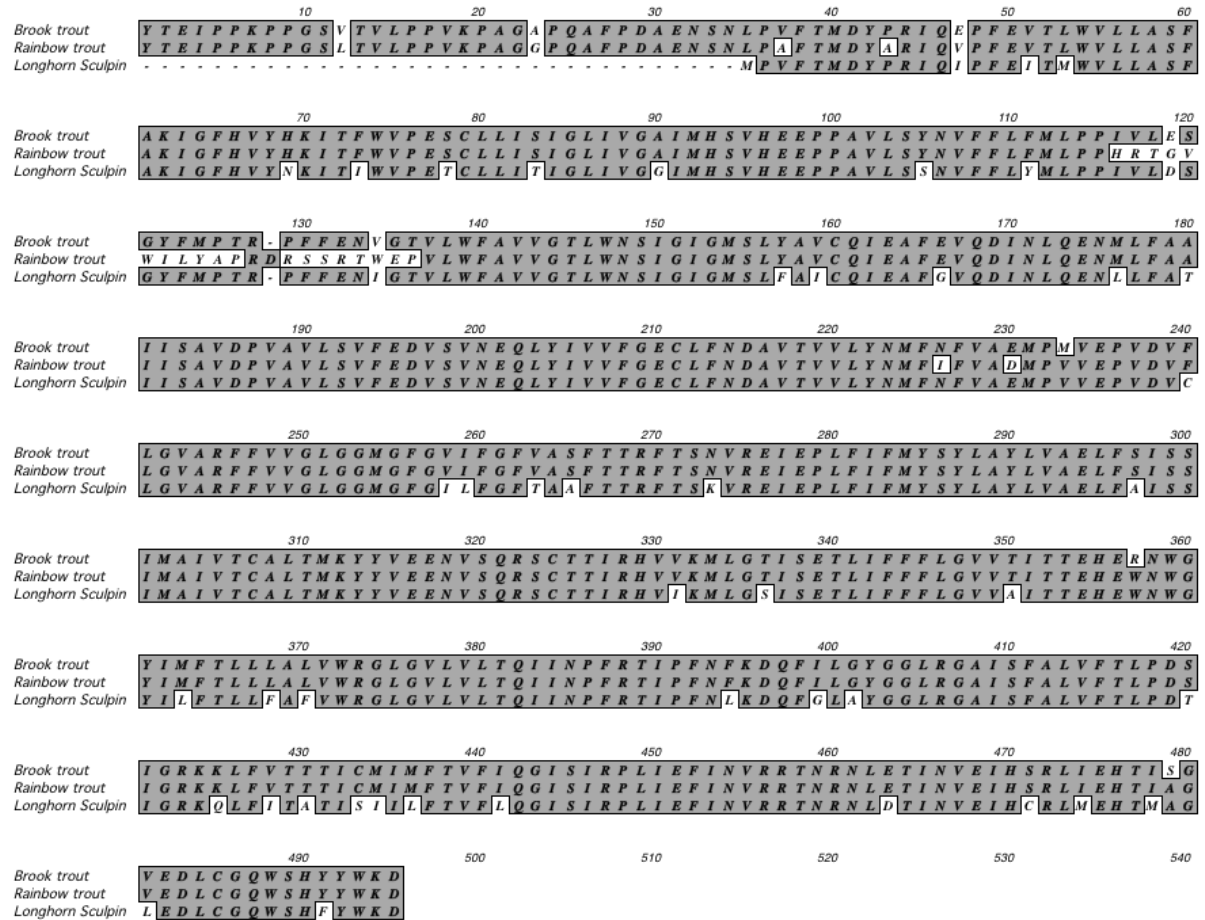

Figure 9. Multiple sequence alignment of NHE2 in teleost fishes. Brook trout NHE2 is found to be similar to rainbow trout NHE2 (94.5% identical; ABO32814.2) and similar to longhorn sculpin NHE2 (90.3% identical; AAD46576.2). Amino acids within grey blocks are identical.

Table 3. Primer sequences used to clone NHE3.

| | Position | Product Size | Sequence |
|----------|----------|--------------|--------------------------------|
| TNHE3-F1 | 1 | 345 | 5' GCCCCTGGTGATTCTGGATAATG 3' |
| TNHE3-R1 | 324 | | 5' ATCTGAGTGATGGAGCCGTTC 3' |
| TNHE3-F2 | 944 | 926 | 5' ATCCCATCTTTTCTGCCGC 3' |
| TNHE3-R2 | 1847 | | 5' TCCGCTTCAGCATTCTTTGG 3' |
| TNHE3-F3 | 397 | 764 | 5' TCACTGAGGGACAGGTCTATGTGG 3' |
| TNHE3-R3 | 1160 | | 5' AACAGAGATGATTCGGCAAACG 3' |
| TNHE3-F5 | 1765 | 519 | 5' AAGTTTCGTGCCAGTTTCTCTGAG 3' |
| THNE3-R5 | 2264 | | 5' ATCCGAGGGGTTCCATTG 3' |

SHOWORF of from 1 to 2100

```

1 TCCAGCATCTCAGGGATACAAATC GTGACCTTTAAGTGGCACCATGTGGAAGCCCTACCTCATCGCCTTATGGACTTGTGGCTGGGGTATCCAAGA 100
F1 1 S S I S G I Q I V T F K W H H V E A P Y L I A L W I L V A G V S K M 34

101 TGGTGGTCGAGCTGAACCACAGCCTGACCAGTGTGATCCCGGAGAGCGCCCTCCTCATCCTCATCGGTTGGATCCTGGGCGGCATCATCTACGGGGCAGA 200
F1 35 V V E L N H S L T S V I P E S A L L I L I G W I L G G I I Y G A D 67

201 CAAGATGCAGACCTTACCCTGACACCTACCGTCTTCTTCTTACCTGCTGCCCAAGTC ATCCTGGACCGGGCTACTTCATGCCCAACAGCTGTTC 300
F1 68 K M Q T F T L T P T V F F F Y L L P Q V I L D A G Y F M P N K L F 100

301 TTCAGCAACATGGGCGCCATCC GGTTTACGCTGTGATTGGCACC GCTGGAACGCTGCCACTGTGGGTCTCGGCCTCTGGGGTGTGGTGGGCGGG 400
F1 101 F S N M G A I L V Y A V I G T C W N A A T V G L G L W G C W L G G A 134

401 CCATGGGTGATATCGACATGGTCTCCTCAGTTCCTGTTTGGGAGTCTAATTGCTGCTGTGACCCTGGCTGTAATGCCGTGTTGAGGAGGT 500
F1 135 M G D I D I G L L Q F L L F G S L I A A V D P V A V I A V F E E V 167

501 CCATGCAACGAGGTCCTGTTTCATCATGGTGTGGGAGTCCCTCCTCAACGATGGTGTACAGTGGTGTTCATGTTGATGTCATTCGTGTCG 600
F1 168 H V N E V L F I M V F G E S L L N D G V T V V L F N V F D A F V S 200

601 CTGGGAGGGGCAGAAATCGATGCTGTAGAGATCATCAAGGCATAATCTCGTCTCTGTTGGTGGCATTCCGAGGCTCCCTGGTGGTATTATCTTTGCTC 700
F1 201 L G G A E I D A V E I I K G I I S F F V V A F G G S L V G I I F A L 234

701 TGCTGGTCTCGTCCCGACCAGATGCACAAGAACCACCCAGATCATCGAGCCAGGCTTCATCTTCATCCTGGGCTACCTCTCCTACCTGACAGCTGAGAT 800
F1 235 L V S L P T R C T K N T Q I I E P G F I F I L G Y L S Y L T A E M 267

801 GCTCTCGTATCCGCTATCCTGTGATCGTGTGTTTGGCATCTGCTGTGAGAATATATCAATGCCAACATGGATGAATGTTCCGTCACCACAGTACGA 900
F1 268 L S L S A I L S I V F C G I C C Q K Y I N A N M D E C S V T T V R 300

901 TACGTCATGAAGGTGTTCCGCAATGGCTCAGAGACCATCATCTTGTCTTCTCGGCATCTCGCCATAGATCCAGCTGATGGGTTTGGAACACAGGCT 1000
F1 301 Y V M K V F A N G S E T I I F V F L G I S A I D P A V W V W N T G F 334

1001 TCATCCTCCTCACACTCCTCTTTCATCTTTGTTGTTGAGTTCATAGGGGCTTTCTTCCTTACCTGGATTCTAAACAAGTACCAGCTGGTTCCTCTGGAGTT 1100
F1 335 I L L T L L F I F V F R F I G V F L L T W I L N K Y R L V P L E F 367

1101 CATTGATCAGGTGGTGTAGCTACGGTGGCCCTCAGAGGGCAGTGYCYATAGCCCTTGTGGCCATGCCGGGTGAGAATAAGTTCAAAGAGAAGAATTTG 1200
F1 368 I D Q V M S Y G G L R G A V A L V A M P G E N K F K E K N L 400

1201 ATGTCAGCACCACCTCATAGTGGTACTTCACTGTCATGCTGCAGGGAATAACCATGAAACCCTGGTCACTGGCTGAAAGTGAAGAGAGCAGCCC 1300
F1 401 M V S T T L I V V Y F T V M L Q G I T M K P L V T W L K V K R A A V 434

1301 TGACAGAACTCACACTAGCTGAAAAATACAGAAATAGGACCTTTGACCACATGCTTGTGCCATAGAGGACATTTCTGGACAAATAGGACATACTACAT 1400
F1 435 T E L T L A E K I Q N R T F D H M L V A I E D I S G Q I G H N Y M 467

1401 GAGAGCAAGTGGCATAACTTTGAGGAAAGTGGTGTGCTGGCTCTTGTATGAAGCCCTCTGCCAGGAAATCCCGTGACTACATATCAACATCTTCCAC 1500
F1 468 R D K W H N F E E R W L C W L L M K P S A R K S R D Y I F N I F H 500

1601 ATAAAGTTTCGTGCCAGTTTCTCTGAGATTATGCGCTGACATCATGGCAGATAATATGGGACCGGATCATGTTCCACTCTCCTCTATCTTACAGGACAT 1700
F1 535 K K F R A S F S E I M P D I M A D N M G P D H V P L S S I L Q D I 567

1701 TGTGCCCTCTGTCTGCCTGGACATGCATGAGCAGGACCTGGAATGAGGGAGTCAGAGGACTTTAATGCACACCATCTACTGCAGCAGCACTTGTACAGA 1800
F1 568 V P S V C L D M H E Q D L E M R E S E D F N A H H L L Q Q H L Y R 600

1801 GGCAGGAAGCAGCACAGACAGGTACAGTCGGAGCCACCTCGAA CCAACAGGGATGAGAATGAGGTGC AGAGATCTTCAGAGAACAATGAGAAGCC 1900
F1 601 G R K Q H R H R Y S R S H L E T N R D E N E V Q E I F Q R T M R S R 634

1901 GTCTAGAGTCATTCAAGTCAGCCAAAATGGGTGTCGCCCTGCCAAGAAGTCCAAACCAAGCATCAAAGAAAAGATAAACCCAAAAGTCCAGGGGTGA 2000
F1 635 L E S F K S A K M G V A P A K K I Q T K H Q K K D K P Q K V R G E 667

2001 AGGCACATTTTCCCCTTCTCCTCGTGTCCGACCTCATAGCCATCCTCTTATAGGCAATGTAATGTGTATGTTGTGTAATTCATGTTATGTCATTTTATG 2100
F1 668 G T F S P F L R V R P H S H P L I G N V M C M L C N F M L C H F * 699

```

Figure 10. Full-length nucleotide sequence for NHE3. The open reading frame of NHE3 in *S. fontinalis* consists of 2100bp (699 amino acids). TNHE3-F1/R1 primers are highlighted in red, TNHE3-F2/R2 primers are highlighted in blue, TNHE3-F3/R3 primers are highlighted in green, and the TNHE3-F5 primer is highlighted in orange.

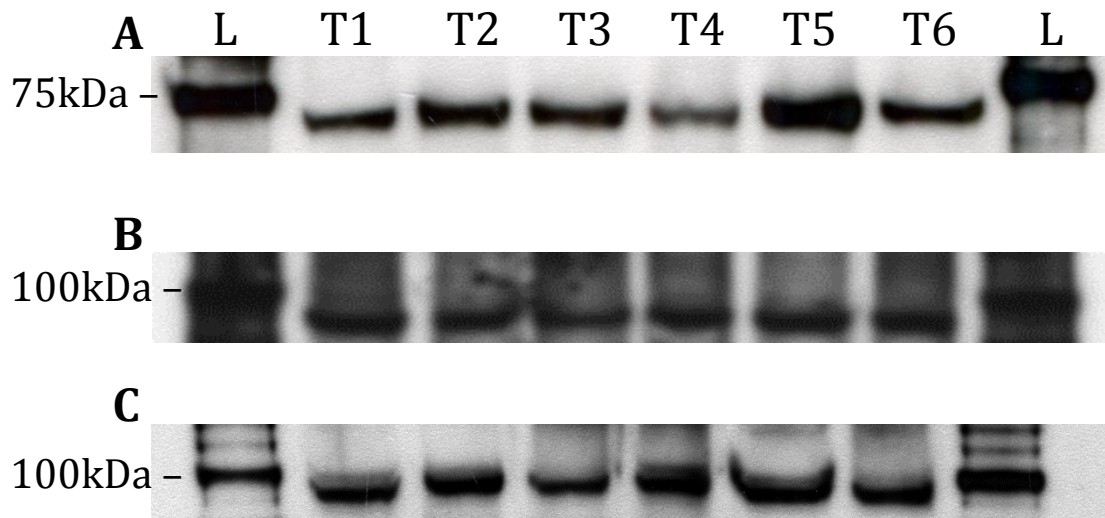

Figure 12. Representative western blot of H^+ -ATPase and NHE3 in gill epithelia. A) Immunolabeling with a monoclonal yeast *anti-H⁺-ATPase* antibody resulted a single immunoreactive band weighing approximately ~65kDa. B) Immunolabeling with a polyclonal sculpin *anti-NHE2* antibody yielded multiple immunoreactive bands, the ~95kDa band band was used in quantification analysis. C) Immunolabeling with a polyclonal rainbow trout *anti-NHE3* antibody resulted in multiple bands; the ~95kDa band was used for quantification analysis.

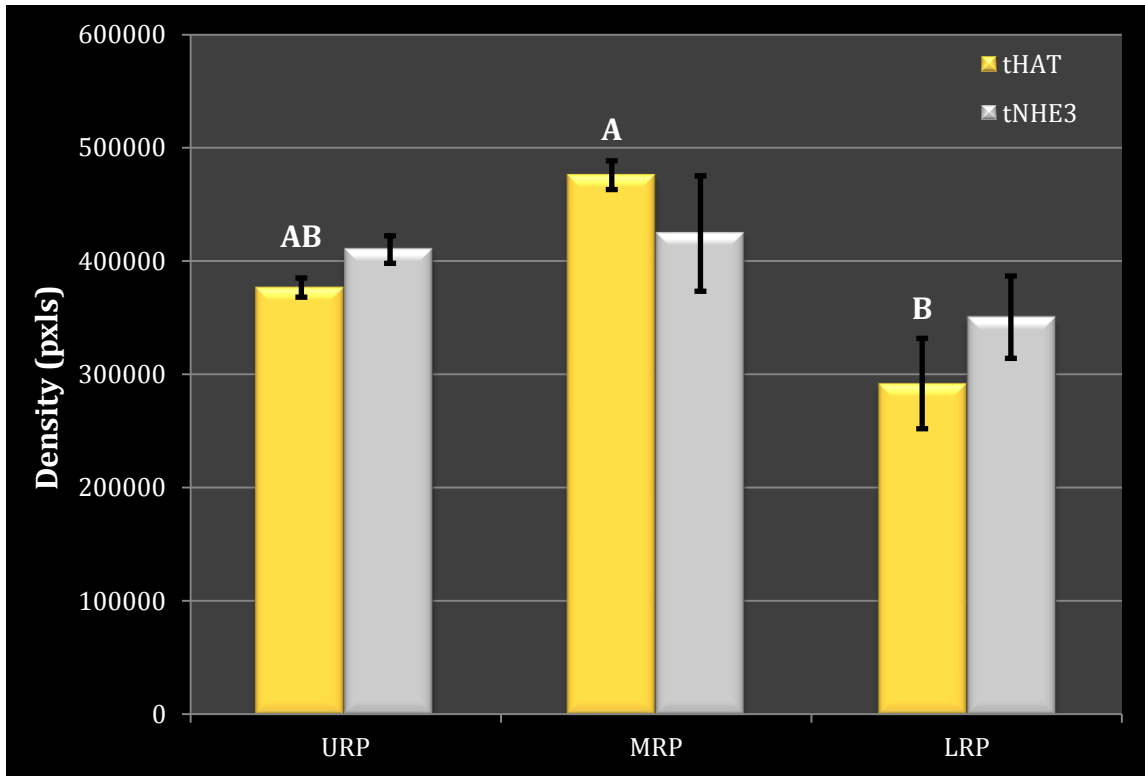

Figure 13. Relative expression of H⁺-ATPase and NHE3. The relative expression of H⁺-ATPase and NHE3 in trout (n = 6) from URP, MRP and LRP were quantified using densitometry (density of pixels). NHE3 expression did not significantly differ throughout all sites. H⁺-ATPase expression significantly (P<0.05) decreased from MRP to LRP, where no statistical significance in expression was detected between URP and MRP as well as URP and LRP. Statistical significance was determined via 2-way ANOVA. All data is presented as mean ± S.E.M.

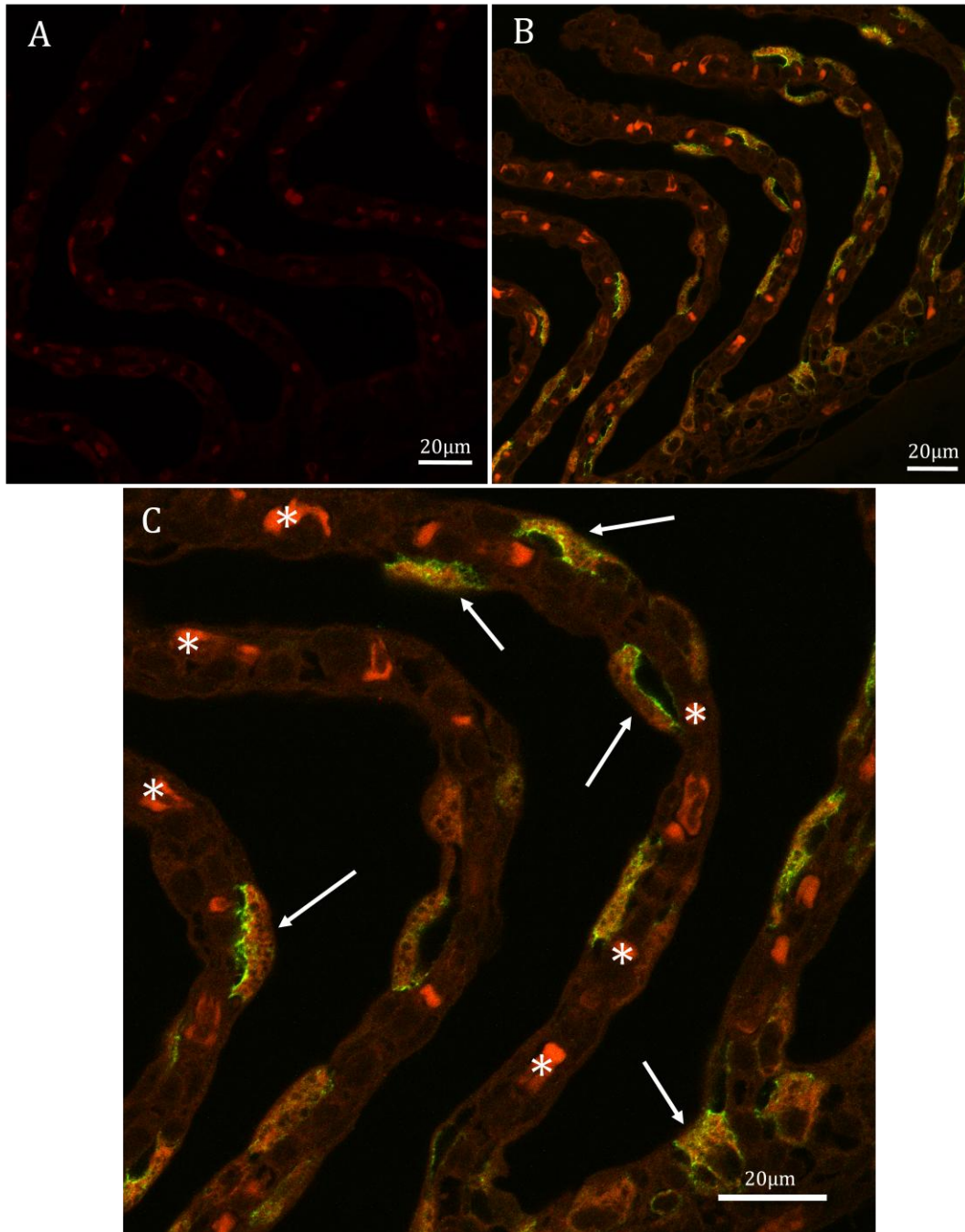

Figure 14. Co-localization of H⁺-ATPase and NKA in gill epithelia. A) Negative control stained in the absence of a primary antibody with secondary (Gt α Ms 488 and Gt α Ms 568). B) Co-localization of H⁺-ATPase (red) and Na⁺/K⁺-ATPase (green) in the mitochondrion-rich cells (MRCs) along the lamellae and in the interlamellar space. C) Higher magnification of co-localization, showing apical and sub-apical expression of H⁺-ATPase in MRCs. It should be noted that red blood cells fluoresced in all sections and are indicated by asterisks. White arrows point to immunoreactive MRCs.

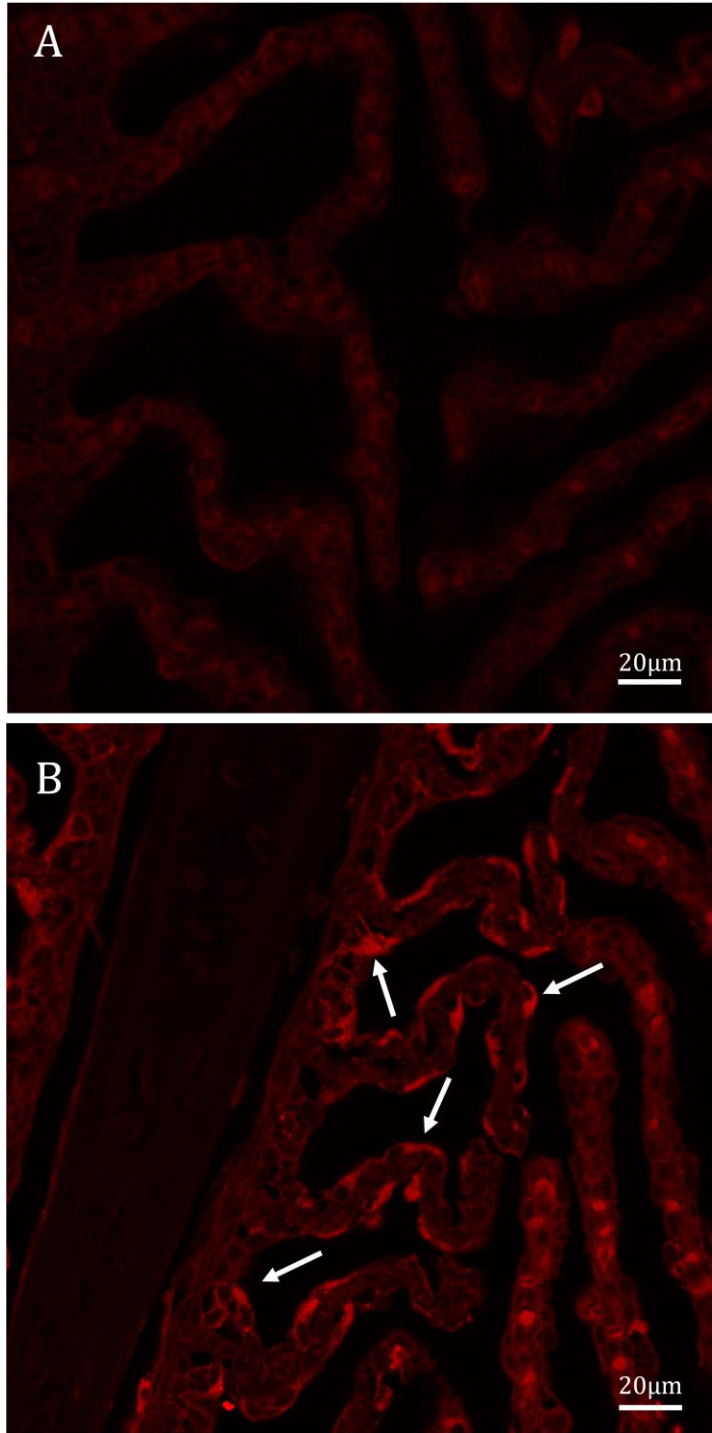

Figure 15. Immunolocalization of H⁺-ATPase in URP brook trout. A) Negative control stained in the absence of primary antibody with secondary antibody (Gt α Ms 568). B) H⁺-ATPase expression localized to the MRCs along the lamellae and the interlamellar space. It should be noted that red blood cells fluoresced in all sections and are indicated by an asterisk. White arrows point to an indicate MRCs. White arrows point to immunoreactive MRCs.

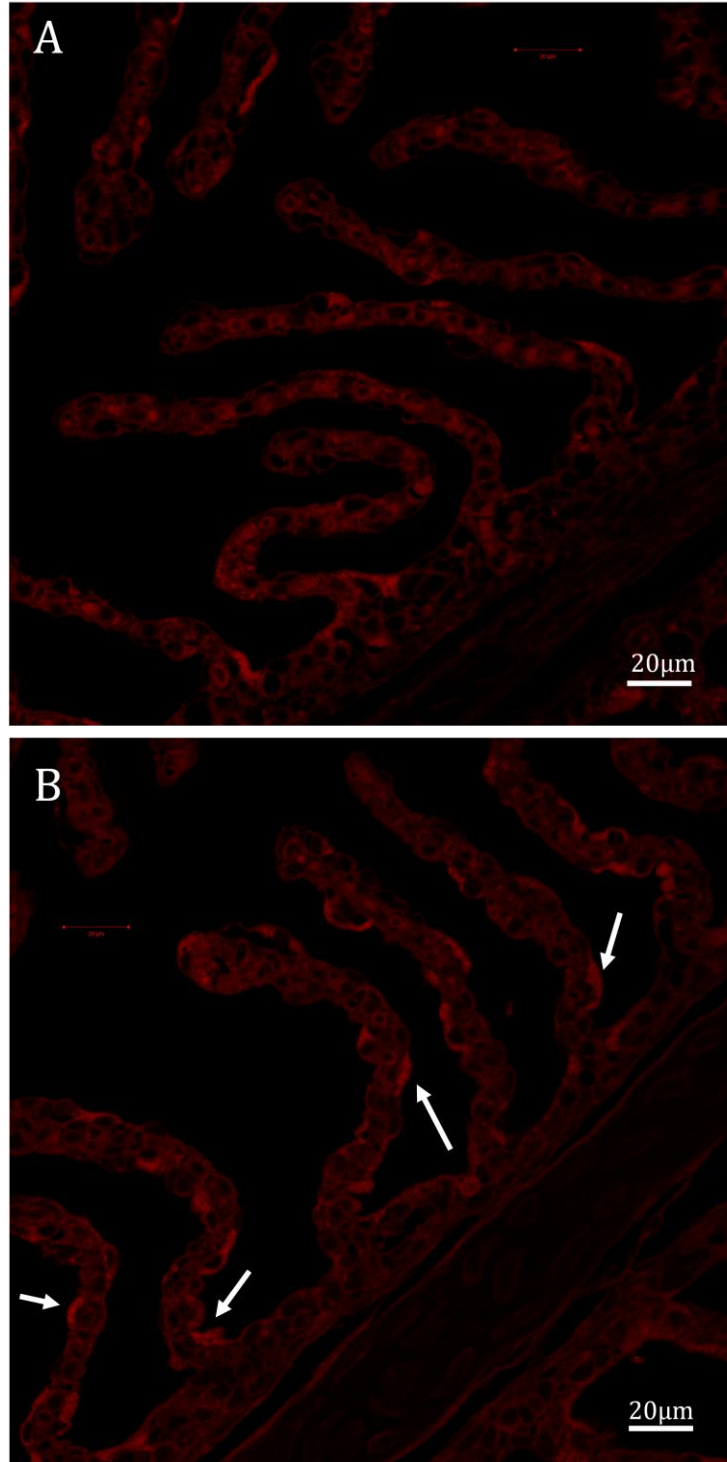

Figure 16. Immunolocalization of H⁺-ATPase in MRP brook trout. A) Negative control stained in the absence of primary antibody with secondary antibody (Gt α Ms 568). B) H⁺-ATPase expression localized to the MRCs along the lamellae and the interlamellar space. White arrows point to immunoreactive MRCs.

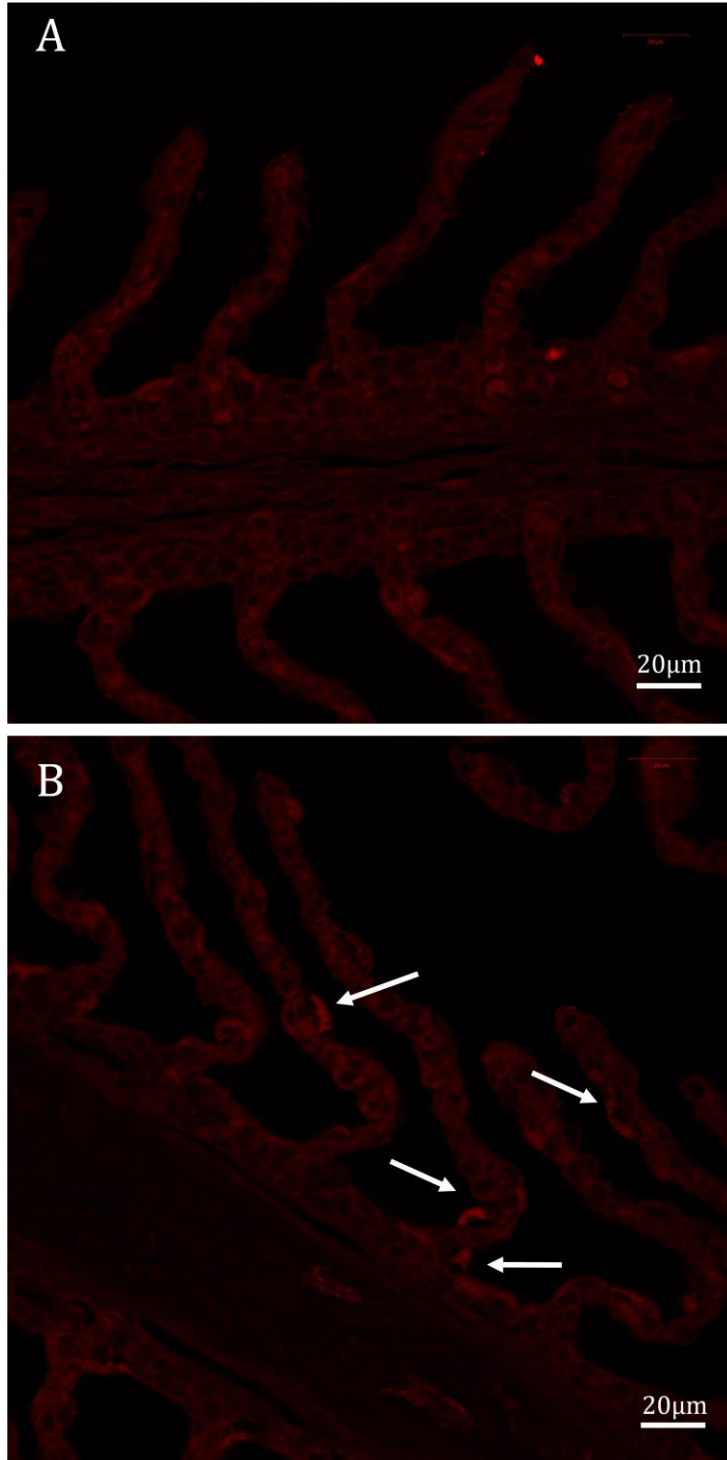

Figure 17. Immunolocalization of H⁺-ATPase in LRP brook trout. A) Negative control stained in the absence of primary antibody with secondary antibody (Gt α Ms 568). B) H⁺-ATPase expression localized to the MRCs along the lamellae and the interlamellar space. White arrows point to immunoreactive MRCs.

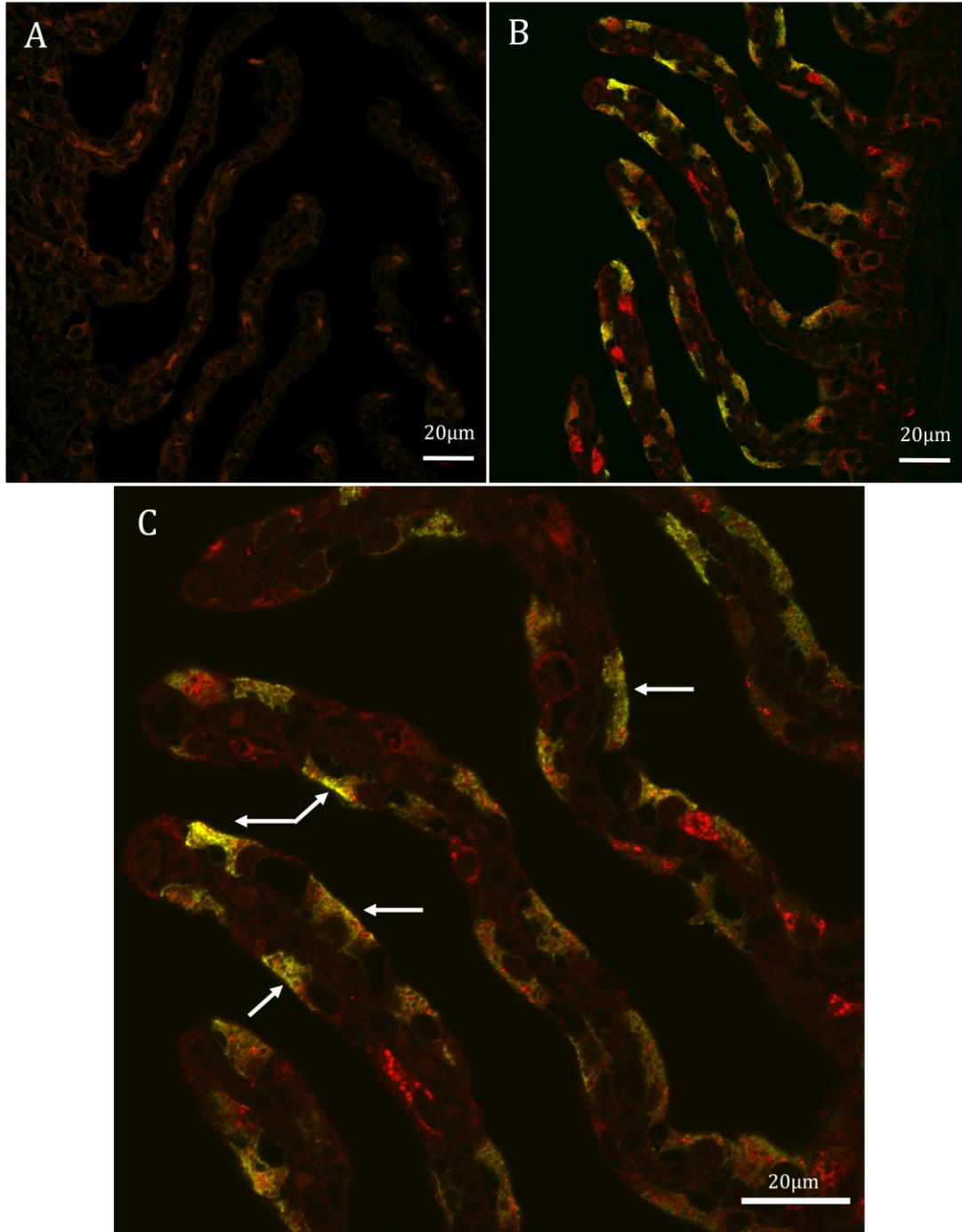

Figure 18. Co-localization of NHE2 and NKA in gill epithelia. A) Negative control stained in the absence of a primary antibody with secondary (Gt α Ms 488 and Gt α Rb 546). B) Co-localization of NHE2 (red) and Na⁺/K⁺-ATPase (green) in the MRCs along the lamellae and in the interlamellar space. C) Higher magnification of co-localization, showing apical and sub-apical punctate staining of NHE2 in the membrane of the MRCs. White arrows point to immunoreactive MRCs.

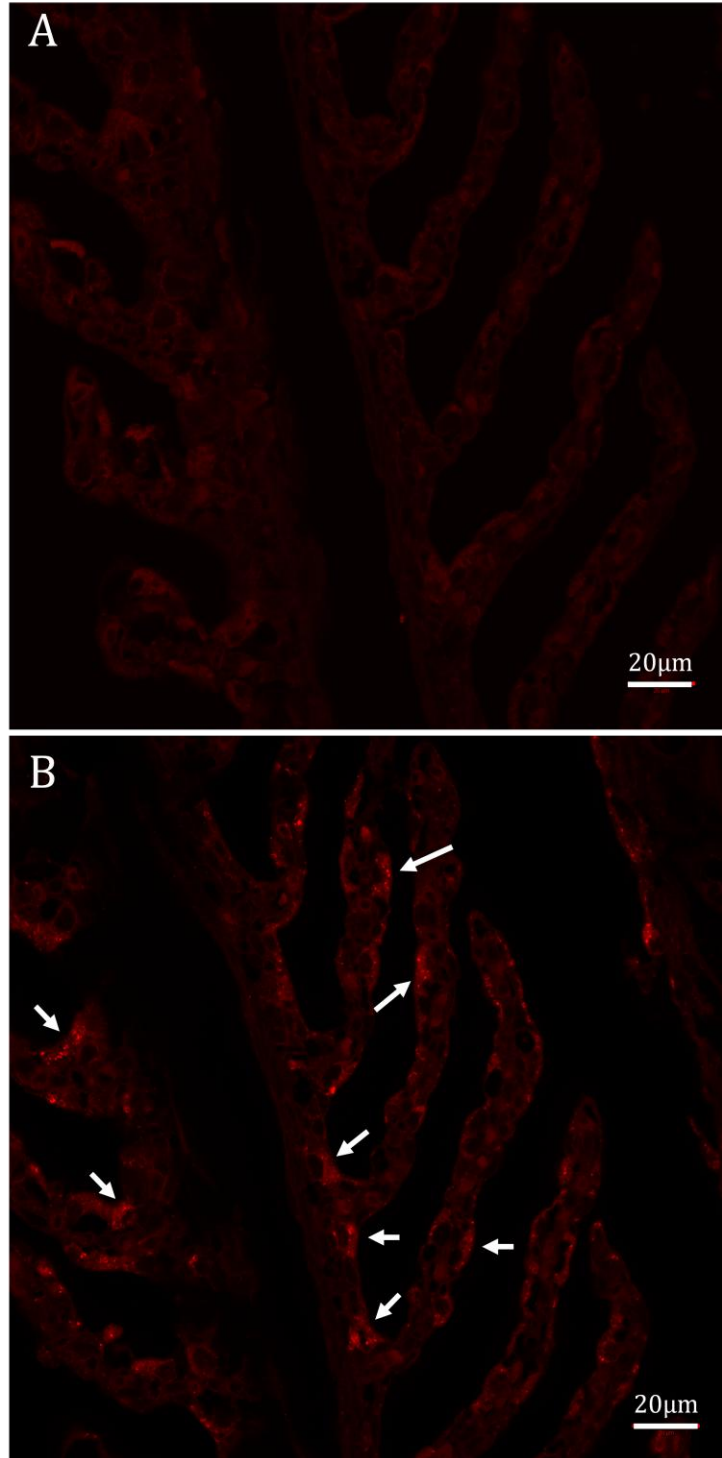

Figure 19. Immunolocalization of NHE2 in URP brook trout. A) Negative control stained in the absence of primary antibody with secondary antibody (Gt α Rb 546). B) NHE2 expression appears punctate and is localized to the MRCs along the lamellae and the interlamellar space. White arrows point to immunoreactive MRCs.

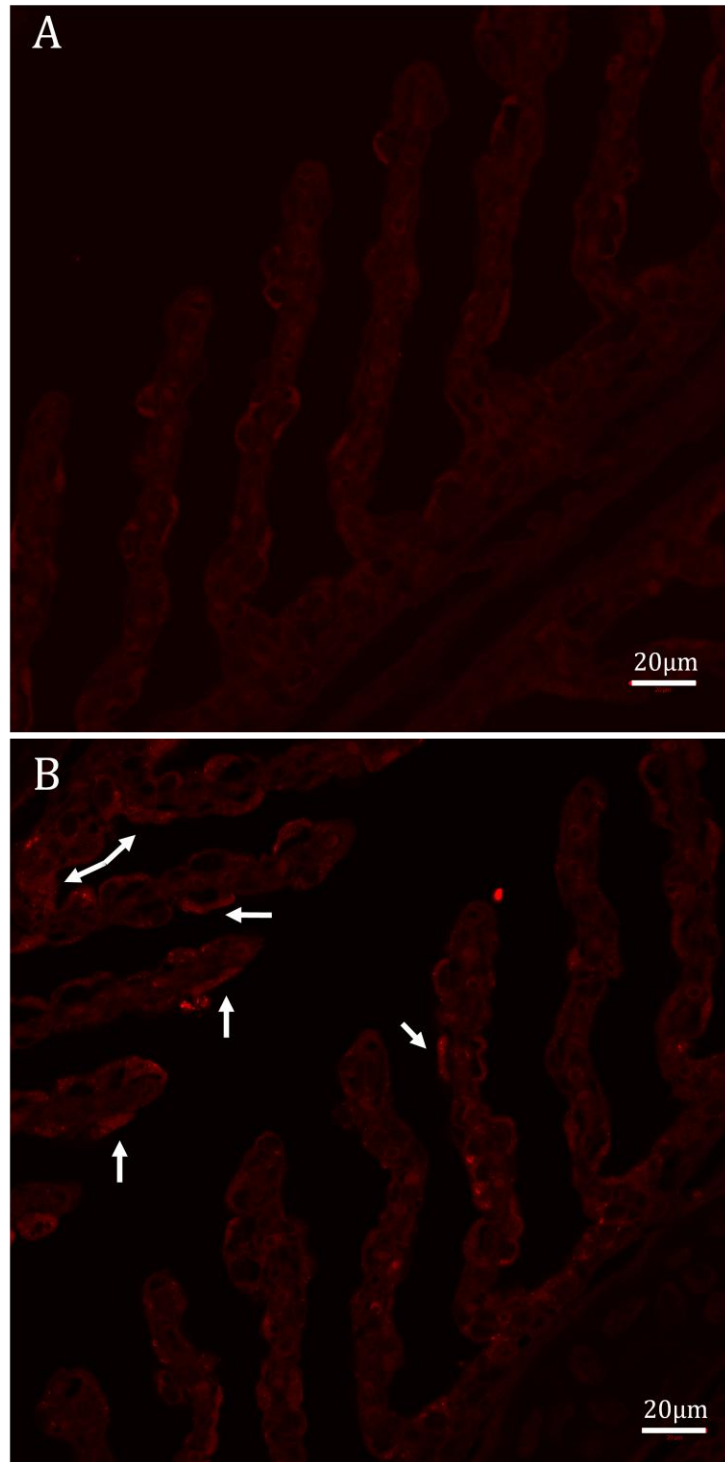

Figure 20. Immunolocalization of NHE2 in MRP brook trout. A) Negative control stained in the absence of primary antibody with secondary antibody (Gt α Rb 546). B) NHE2 expression localized to the MRCs along the lamellae and the interlamellar space. White arrows point to immunoreactive MRCs.

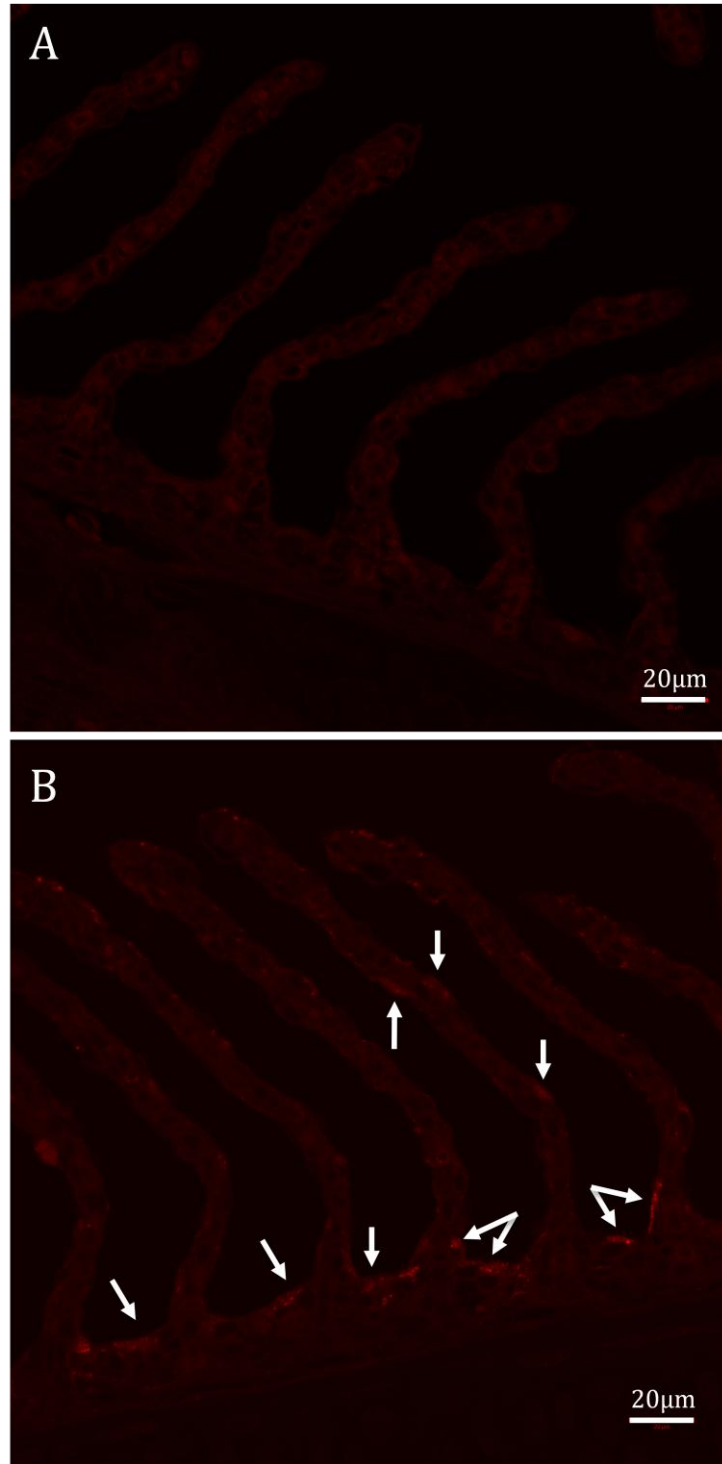

Figure 21. Immunolocalization of NHE2 in LRP brook trout. A) Negative control stained in the absence of primary antibody with secondary antibody (Gt α Rb 546). B) NHE2 expression is localized to few MRCs along the lamellae and primarily to the MRCs within the interlamellar region. White arrows point to immunoreactive MRCs.

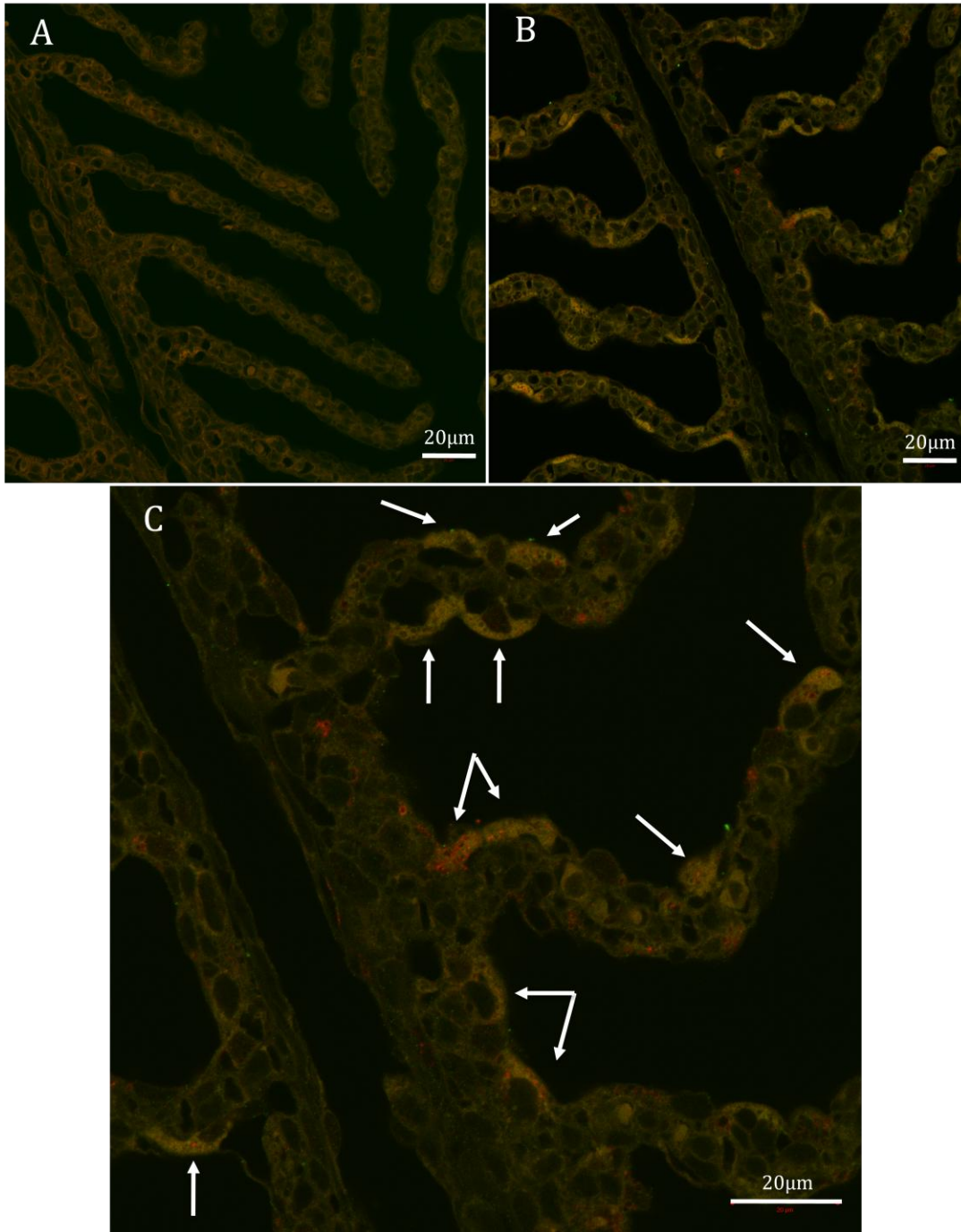

Figure 22. Co-localization of H⁺-ATPase and NHE2 in gill epithelia. A) Negative control stained in the absence of primary antibody with secondary antibody (Gt α Ms 488 and Gt α Rb 546). B) Co-localization of NHE2 (red) and H⁺-ATPase (green) expression in the MRCs along the lamellae and in the interlamellar space. C) Higher magnification of the co-localization, showing NHE2 expression stained punctate along the apical membrane of MRCs and H⁺-ATPase expression in the apical and sub-apical region of MRCs. White arrows point to immunoreactive MRCs.

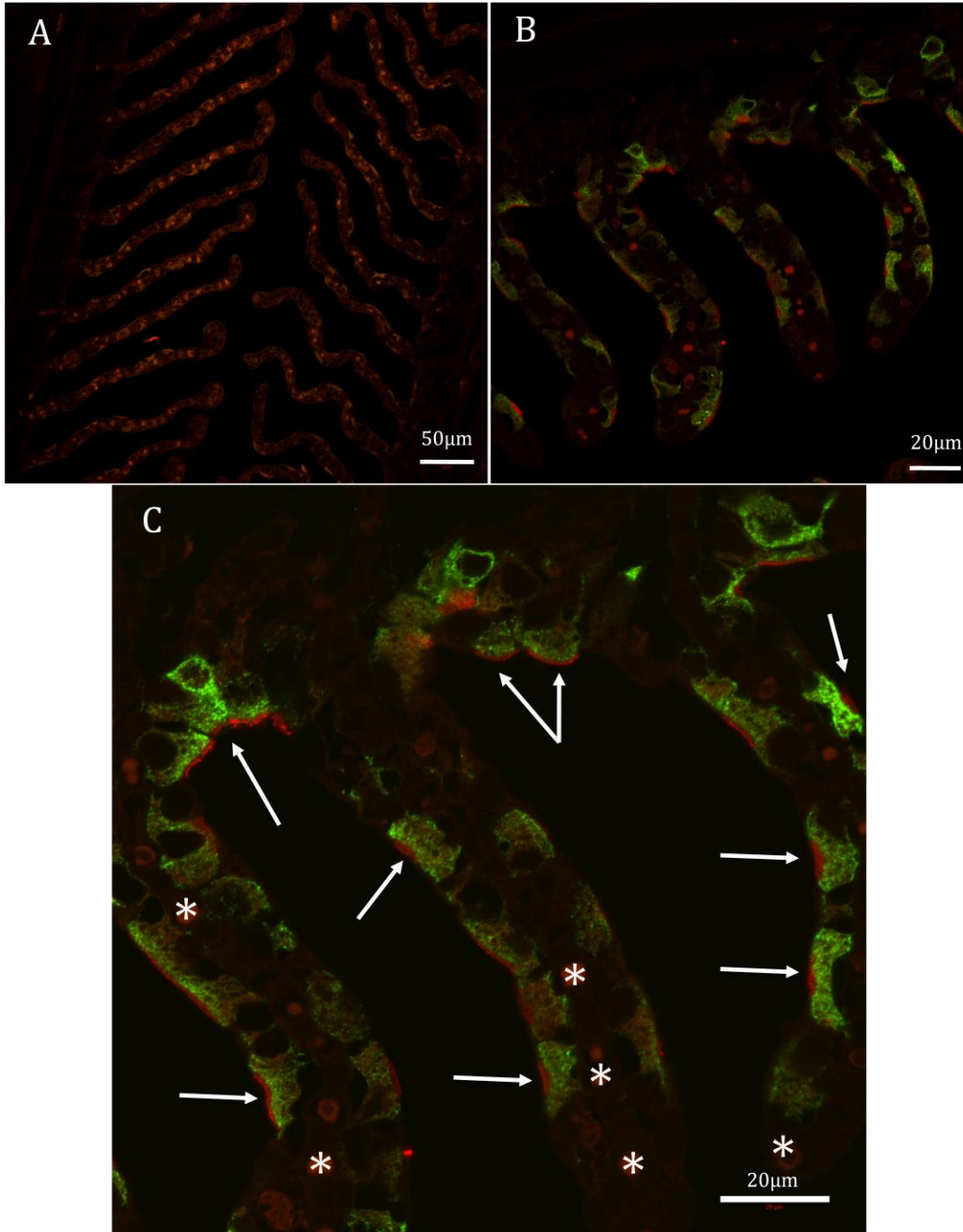

Figure 23. Co-localization of NHE3 and NKA in gill epithelia. A) Negative control stained in the absence of primary antibody with secondary antibody (Gt α Ms 488 and Gt α Rb 546). B) Co-localization of NHE3 (red) and Na⁺/K⁺-ATPase (green) expression in the mitochondrion-rich cells (MRCs) along the lamellae and in the interlamellar space. C) Higher magnification of the co-localization, showing NHE3 expression specifically localized to the apical membrane of the MRCs. It should be noted that red blood cells fluoresced in all sections and are indicated by asterisks. White arrows point to immunoreactive MRCs.

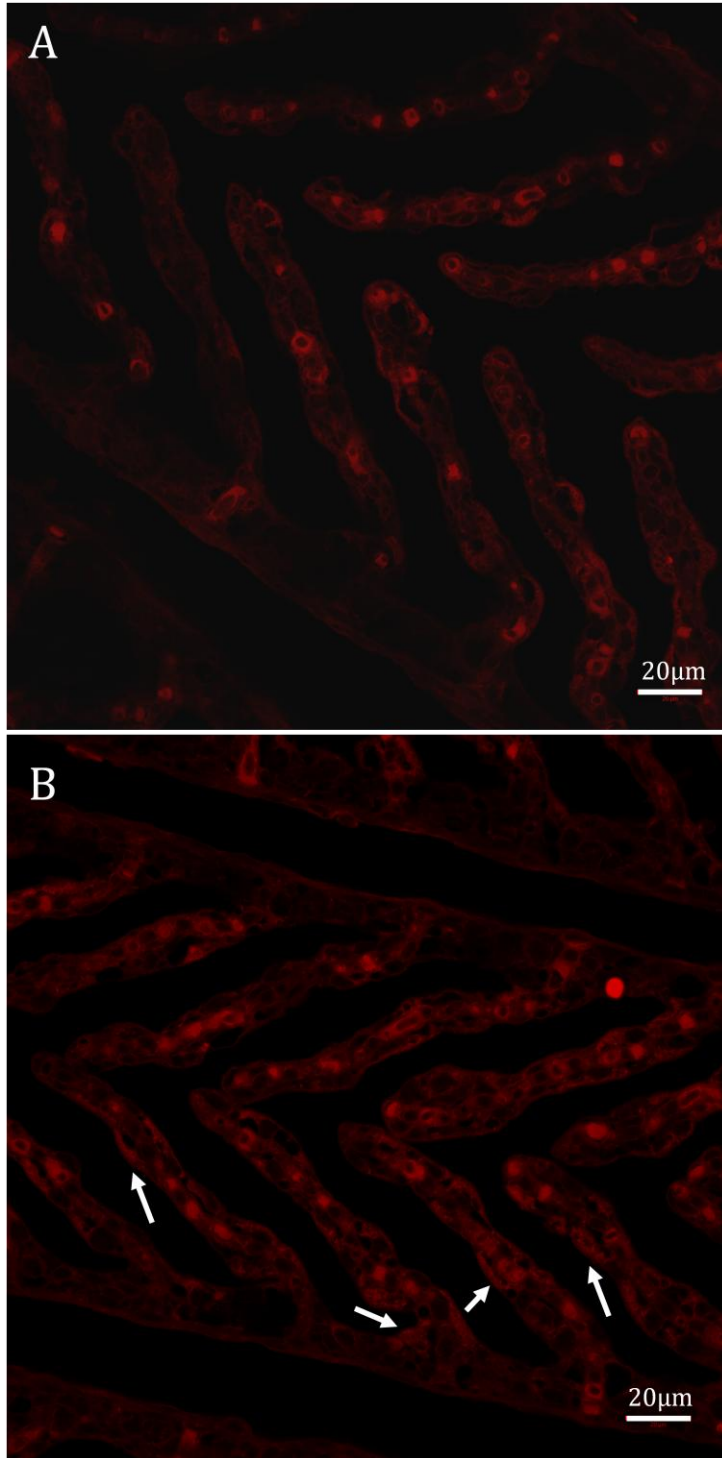

Figure 24. Immunolocalization of NHE3 in URP brook trout. A) Negative control stained in the absence of primary antibody with secondary antibody (Gt α Ms 546). B) NHE3 expression localized to the MRCs along the lamellae and few MRCs within the interlamellar region. White arrows point to immunoreactive MRCs.

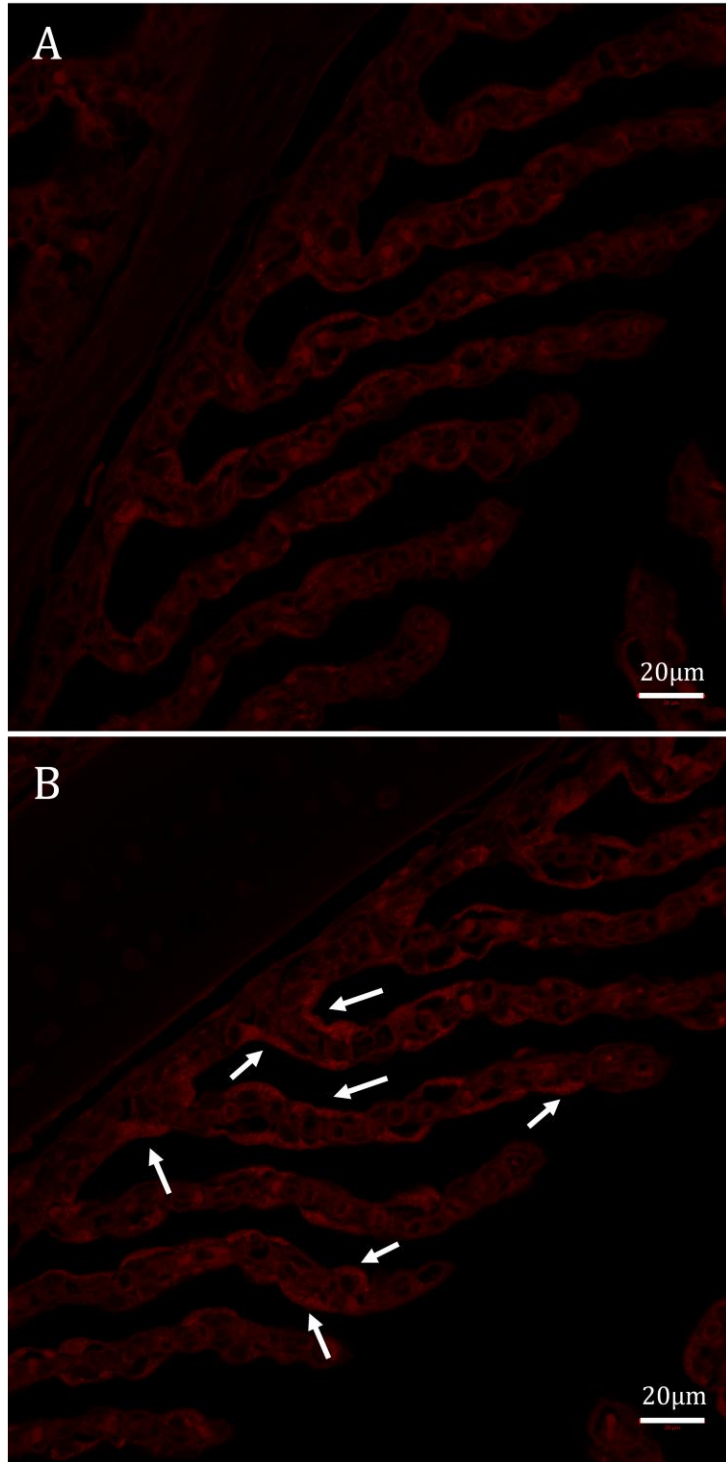

Figure 25. Immunolocalization of NHE3 in MRP brook trout A) Negative control stained in the absence of primary antibody with secondary antibody (Gt α Ms 546). B) NHE3 expression localized to the MRCs along the lamellae and the interlamellar region. White arrows point to immunoreactive MRCs.

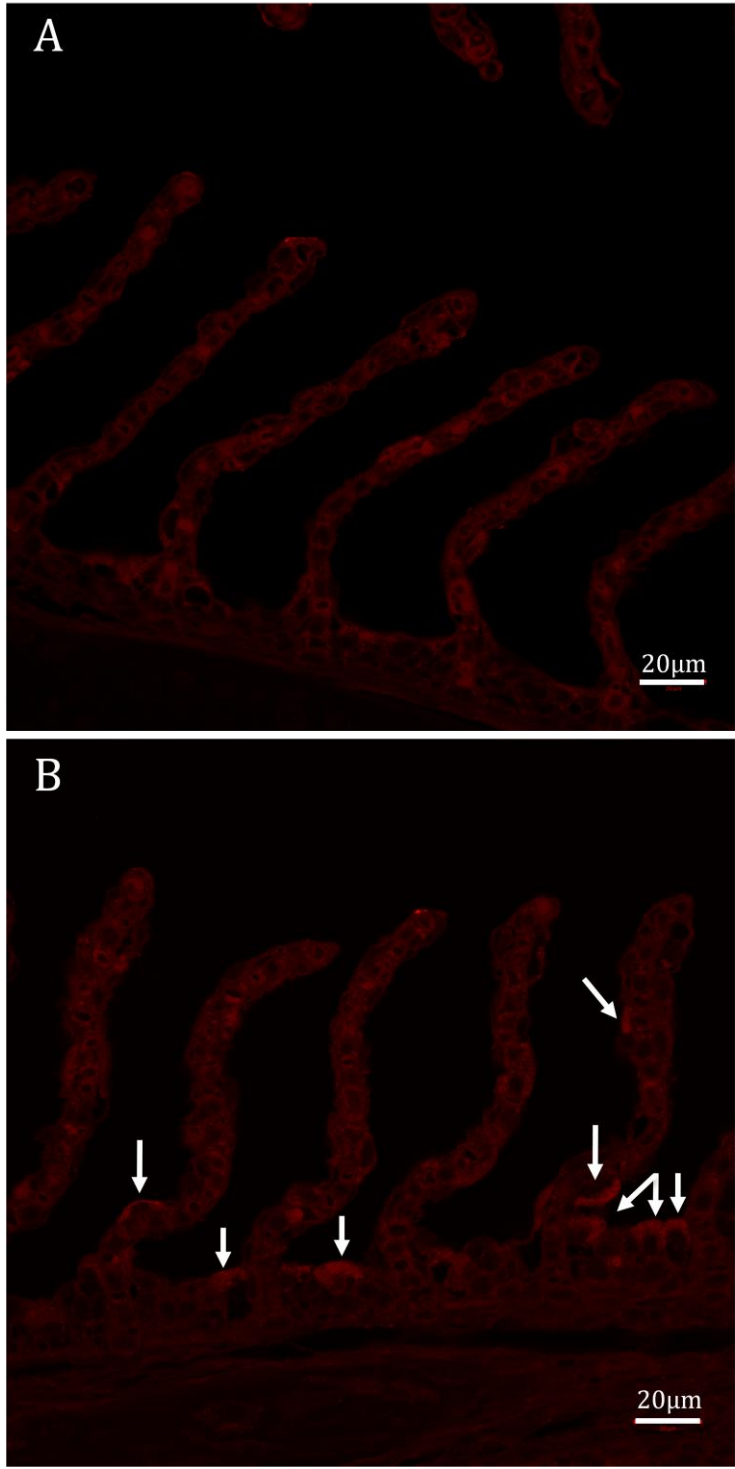

Figure 26. Immunolocalization of NHE3 in LRP brook trout. A) Negative control stained in the absence of primary antibody with secondary antibody (Gt α Ms 546). B) NHE3 expression localized to the MRCs within the interlamellar region of the filament. White arrows point to immunoreactive MRCs.

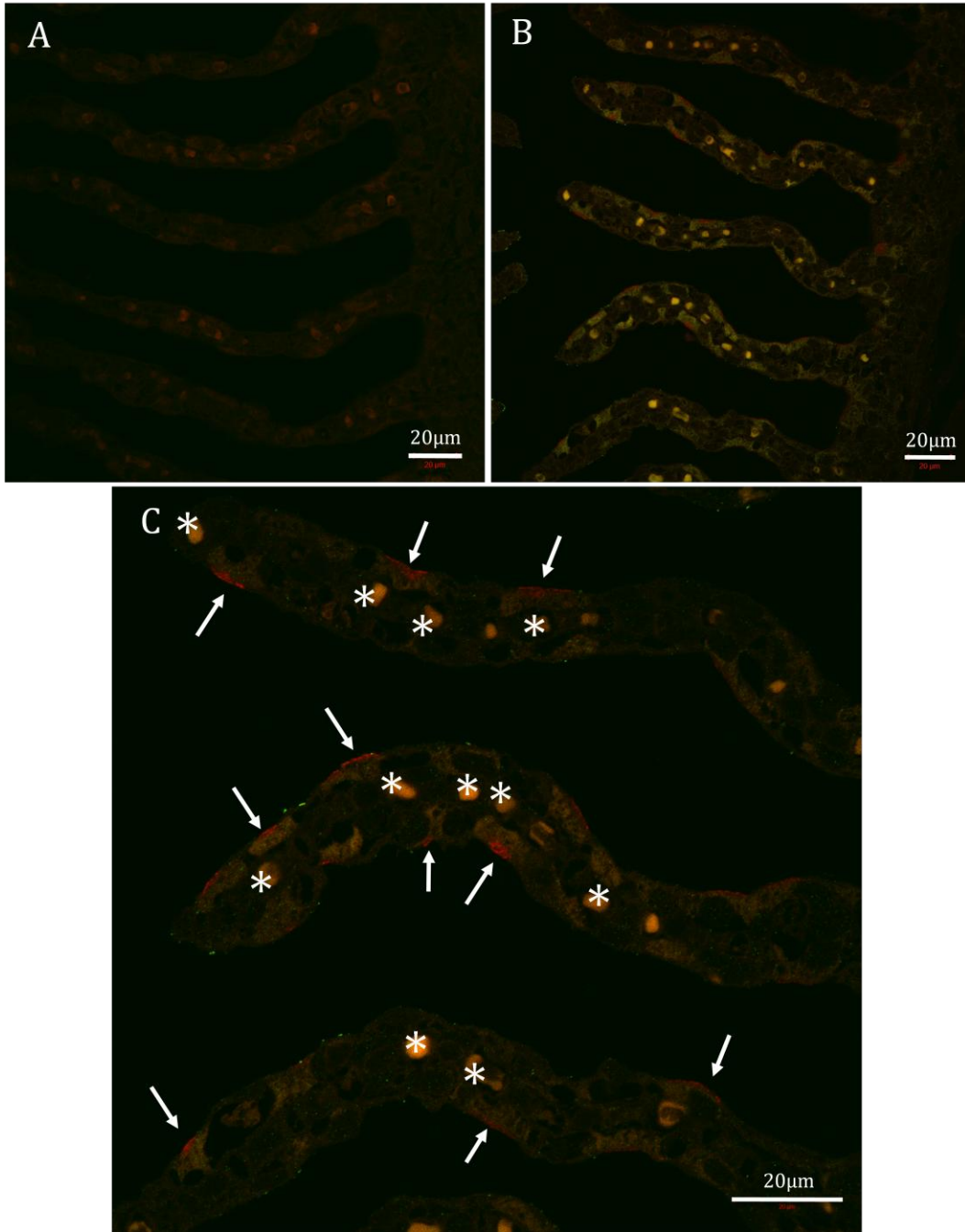

Figure 27. Co-localization of H⁺-ATPase and NHE3 in gill epithelia. A) Negative control stained in the absence of primary antibody with secondary antibody (Gt α Ms 488 and Gt α Rb 546). B) Co-localization of NHE3 (red) and H⁺-ATPase (green) expression in the mitochondrion-rich cells (MRCs) along the lamellae and in the interlamellar space. C) Higher magnification of the co-localization, showing NHE3 expression specifically localized to the apical membrane of the MRCs and H⁺-ATPase expression in the sub-apical zone. It should be noted that red blood cells fluoresced in all sections and are indicated by asterisks. White arrows point to immunoreactive MRCs.

REFERENCES CITED

- Alexander, R. T. and Grinstein, S.** (2009). Tethering, recycling and activation of the epithelial sodium-proton exchanger, NHE3. *J. Exp. Biol.* **212**, 1630-1637.
- Alexander, R. T., Valentin, J., Yeung, T., Furuya, W., Peltekova, I., Boucher, A., Zasloff, M., Orłowski, J. and Grinstein, S.** (2011). Membrane surface charge dictates the structure and function of the epithelial Na⁺/H⁺ exchanger. *EMBO J.* **30**, 679-691.
- Arai, H., Terres, G., Pink, S. and Forgac, M.** (1988). Topography and subunit stoichiometry of the coated vesicle proton pump. *J. Biochem.* **25**, 8796-8802.
- Avella, M. and Bornancin, M.** (1989). A new analysis of ammonia and sodium transport through the gills of the freshwater rainbow trout (*Salmo gairdneri*). *J. Exp. Biol.* **142**, 155-175.
- Biemesderfer, D., Rutherford, P. A., Naqy, T., Pizzonia, J. H., Abu-Alfa, A. K. and Aronson, P. S.** (1997). Monoclonal antibodies for high-resolution localization of NHE3 in adult and neonatal rat kidney. *Am. J. Physiol.* **273**, 289-299.
- Bivens, R. D., Strange, R. J. and Peterson, D. C.** (1985). Current distribution of the native brook trout in the Appalachian region of Tennessee. *J. Tenn. Acad. Sci.* **60**, 101-105.
- Brown, D., Hirsch, S. and Gluck, S.** (1988). Localization of a proton-pumping ATPase in rat kidney. *J. Clin. Invest.* **82**, 2114-2126.
- Brown, D., Paunescu, T G., Breton, S. and Marshansky, V.** (2009). Regulation of the V-ATPase in kidney epithelia cells: dual role in acid-base homeostasis and vesicle trafficking. *J. Exp. Biol.* **212**, 1762-1772.
- Cai, M., Schwartz, J. S., Robinson, R. B., Moore, S. E. and Kulp, M. A.** (2010). Long-term effects of acidic deposition on water quality in a high-elevation Great Smoky Mountains National Park watershed: Use of an ion input-output budget. *Water Air Soil Pollut.* **209**, 143-156.
- Castro, M. S. and Morgan, R. P.** (2000). Input-output budgets of major ions for a forested watershed in Western Maryland. *Water Air Soil Pollut.* **119**, 121-137.

- Catches, J. S., Burns, J. M., Edwards, S. L. and Claiborne, J. B.** (2006). Na^+/H^+ antiporter, V-H^+ -ATPase and Na^+/K^+ -ATPase immunolocalization in a marine teleost (*Myoxocephalus octodecemspinosus*). *J Exp Biol.* **209**, 3440-3447.
- Claiborne, J. B.** (1998) Acid-Base regulation. The physiology of fishes. E. DH. Boca Raton, CRC Press: 179-200.
- Claiborne, J. B., Blackston, C. R., Choe, K. P., Dawson, D. C., Harris, S. P., Mackenzie, L. A. and Morrison-Shetlar, A. I.** (1999). A mechanism for branchial acid excretion in marine fish: identification of multiple Na^+/H^+ antiporter (NHE) isoforms in gills of two seawater teleosts. *J. Exp. Biol.* **202**, 315-24.
- Claiborne, J. B., Compton-McCullough D. and Walkton J. S.** (2000). Branchial acid-base transfers in the euryhaline oyster toadfish (*Opasnus tau*) during exposure to dilute seawater. *J. Fish Biol.* **55**, 1539-1544.
- Claiborne, J. B., Edwards, S. L. and Morrison-Shetlar, A. I.** (2002). Acid-base regulation in fishes: Cellular and molecular mechanisms. *J. Exp. Zoo.* **293**, 302-319.
- Claiborne, J. B., Choe, K. P., Morrison-Shetlar A. I., Weakley, J. C., Havrid, J., Freiji, A., Evans, D. H. and Edwards S. L.** (2008). Molecular detection and immunological localization of gill Na^+/H^+ exchanger in the dogfish (*Squalus acanthias*). *Am. J. Physiol. Regul. Integr. Comp. Physiol.* **294**, 1092-11022.
- Cook, R. B., Elwood, J. W., Turner, R. R., Bogle, M. A., Mulholland, P. J. and Palumbo, A.V.** (1994). Acid-base chemistry of high-elevated streams in the Great Smoky Mountains. *Water Air Soil Pollut.* **72**, 331-356.
- Dambrine , E., Pollier, B., Poszwa, A., Ranger, J., Probst, A., Viville, D., Biron, P. and Granier, A.** (1998). Evidence of current soil acidification in spruce stands in the Vosges Mountains, north-eastern France. *Water Air Soil Pollut.* **105**, 43-52.
- Deyton, E. B., Schwartz, J. S., Robinson, R. B., Neff, K. J., Moore, S. E. and Kulp, M. A.** (2009). Characterizing episodic stream acidity during stormflows in the Great Smoky Mountains National Park. *Water Air Soil Pollut.* **196**, 3-18.
- Driscoll, C. T., Lawrence, G. B., Bulger, A. J., Bulter, T. J., Cronan, C. S., Eagar, C., Lambert, K. F., Likens, G. E., Stoddard, J. L. and Weathers, K. C.** (2001). Acidic deposition in the northeastern United States: Sources and inputs, ecosystem effects, and management strategies. *BioScience* **51**, 180-197.
- Edwards, S. L.** (2000). *The identification of the Na^+/H^+ exchanger in the gills of fishes*. Dissertation, Deakin University, Geelong, Victoria, Australia.

- Edwards, S. L., Tse, C. M. and Toop T.** (1999). Immunolocalisation of NHE3-like immunoreactivity in the gills of the rainbow trout (*Oncorhynchus mykiss*) and the blue-throated wrasse (*Pseudolabrus tetrivus*). *J. Anat.* **195**, 465-469.
- Edwards, S. L., Claiborne, J. B., Morrison-Shetlar, A. I. and Toop, T.** (2001). Expression of Na (+) /H (+) exchanger mRNA in the gills of the Atlantic hagfish (*Myxine glutinosa*) in response to metabolic acidosis. *Comp. Biochem. Physiol. A Mol. Integr. Physiol.* **130**, 81-91.
- Edwards, S. L., Donald, J. A., Toop, T., Donowitz, M. and Tse, C.-M.** (2002). Immunolocalization of sodium/proton exchanger-like proteins in the gills of elasmobranchs. *Comp. Biochem. Physiol. A.* **131**, 257-265.
- Edwards, S. L., Wall, B. P., Morrison-Shetlar, A., Sligh, S., Weakley, J. C., and Claiborne, J. B.** (2005). The effect of environmental hypercapnia and salinity on the expression of NHE-like isoforms in the gills of a euryhaline fish (*Fundulus heteroclitus*). *J. Exp. Biol.* **303a**, 464-475.
- Edwards, S. L., Weakley, J. C., Diamanduros, A. W. and Claiborne, J. B.** (2010). Molecular identification of Na⁺-H⁺ exchanger isoforms (NHE2) in the gills of the euryhaline teleost *Fundulus heteroclitus*. *J. Fish Biol.* **76**, 415-426.
- Ehrenfeld, J. and Klein, U.** (1997). The key role of the H⁺ V-ATPase in acid-base balance and Na⁺ transport processes in frog skin. *J. Exp. Biol.* **200**, 247-256.
- Evans, D. H., Piermarini, P. M. and Choe, K. P.** (2005). The multifunctional fish gill: Dominant site of gas exchange, osmoregulation, acid-base regulation, and excretion of nitrogenous waste. *Physiol. Rev.* **85**, 97-177.
- Evans, D. H.** (2008). Teleost fish osmoregulation: What we have learned since August Krogh, Homer Smith, and Ancel Keys. *Amer. J. Physiol.* **295**, 704-713.
- Evans, D. H.** (2010). Freshwater fish gill ion transport: August Krogh to morpholinos and microprobes. *Acta. Physiol.* **202**, 349-359.
- Evans, H. E., Dillon, P. J. and Molot, L. A.** (1997). The use of mass balance investigations in the study of biogeochemical cycle of sulfur. *Hydro. Proces.* **11**, 765-782.
- Finberg, K. E., Wagner, C. A., Bailey, M. A., Paunescu, T. G., Breton, S., Brown D., Giebisch, G., Geibel, J. P. and Lifton R. P.** (2005). The B1-subunit of the H⁺-ATPase is required for maximal urinary acidification. *Proc. Natl. Acad. Sci. USA.* **102**, 13616-13621.

- Furukawa, F., Watanabe, S., Inokuchi, M. and Kaneko, T.** (2011). Responses of gill mitochondria-rich cells in Mozambique tilapia exposed to acidic environments (pH 4.0) in combination with different salinities. *Comp. Biochem. and Physiol., Part A.* **158**, 468-476.
- Galvez, F., Reid, S. D., Hawkins, G. and Goss, G. G.** (2002). Isolation and characterization of mitochondria-rich cell types from the gill of freshwater rainbow trout. *Am. J. Physiol.* **282**, 658-668.
- Garcia-Romeu, F. and Maetz, J.** (1964). The mechanism of sodium and chloride uptake by the gills of a freshwater fish, *Carassius auratus*. I. Evidence for an independent uptake of sodium and chloride. *J. Gen. Physiol.* **47**, 1195-1207.
- Goss, G. G., Perry, S. F., Fryer, J. N. and Laurent, P.** (1998). Gill morphology and acid-base regulation in freshwater fishes. *Comp. Biochem. and Physiol.* **119A**, 107-115.
- Goss, G. G., Adamia, S. and Galvez, F.** (2001). Peanut lectin binds to a subpopulation of mitochondria-rich cells in the rainbow trout gill epithelium. *Am. J. Physiol. Regul. Integr. Comp. Physiol.* **281**, 18-25.
- Henry R. P.** (1996). Multiple roles of carbonic anhydrase in cellular transport and metabolism. *Annu. Rev. Physiol.* **58**, 523-538.
- Herlihy, T., Kaufmann, P. R., Mitch M. E. and Brown, D. D.** (1990). Regional estimates of acid mine drainage impact on streams in the Mid-Atlantic and Southeastern United States. *Water Air Soil Pollut.* **50**, 91-107.
- Hirata, T., Kaneko, T., Ono, T., Nakazato, T., Furukawa, N., Hasegawa, S., Wakabayashi, S., Shigekawa, M., Chang, M., Romero, M. F. and Hirose, S.** (2003). Mechanism of acid adaptation of a fish living in a pH 3.5 lake. *Am. J. Physiol. Regul. Integr. Comp. Physiol.* **284**, 1199-1212.
- Imamura, H., Nakano, M., Noji, H., Muneyuki, E., Ohkuma, S., Yoshida, M. and Yokoyama K.** (2002). Evidence for rotation of V₁-ATPase. *Proc. Nat.l Acad. Sci. USA.* **100**, 2312-2315.
- Ivanis, G., Esbaugh, A. J. and Perry, S. F.** (2008). Branchial expression and localization of SLC9A2 and SLC 9A3 sodium/hydrogen exchangers and their possible role in acid-base regulation in freshwater rainbow trout (*Oncorhynchus mykiss*). *J. Exp. Biol.* **211**, 2467-2477.
- Jefferies, K. C., Cipriano, D. J. and Forgac M.** (2008). Function, structure and regulation of vacuolar (H⁺)-ATPases. *Arch Biochem Biophys.* **476**, 33-42.

- Kane, P. M., Kuehn, M. C., Howald-Stevenson, I. and Stevens, T. H.** (1992). Assembly and targeting of peripheral and integral membrane subunits of the yeast vacuolar H⁺-ATPase. *J. Biol. Chem.* **267**, 447-454.
- Kaneko, T., Hasegawa, S., Uchida, K., Ogasawara, T., Oyagi, A. and Hirano, T.** (1999). Acid tolerance of Japanese dace (a Cyprinid Teleost) in Lake Osorezan, a remarkable acid lake. *Zoo. Soc. Jp.* **16**, 871-877.
- Karas, N.** (1997). The fall and rise of brook trout in Southern Appalachia. *Brook Trout*. Lyons and Burford, New York.
- Kerstetter, T. H., Kirschner L. B. and Rafuse D. D.** (1970). On the mechanisms of sodium ion transport by the irrigated gills of rainbow trout (*Salmo gairdneri*). *J. Gen. Physiol.* **56**, 342-359.
- Krogh, A.** (1937). Osmotic regulation by active absorption of ions in freshwater animals. *Skandinavisches Archiv Fur Physiologie.* **77**, 50-52.
- Laurent, P., Goss, G. G. and Perry, S. F.** (1994). Proton pumps in fish gill pavement cells? *Arch. Int. Physiol. Biochem. Biophys.* **102**, 77-79.
- Ledoussal, C., Woo, A. L., Marian, L. M. and Shull, G. E.** (2001). Loss of the NHE2 Na⁺/H⁺ exchanger has no apparent effect on diarrheal state of NHE3-deficient mice. *Gastr. Liver Physiol.* **281**, G1385-G1396.
- Lin, C. H. and Randall, D.** (1991). Evidence for the presence of an electrogenic proton pump on the trout gill epithelium. *J. Exp. Biol.* **161**, 119-134.
- Lin, C. H. and Randall, D.** (1993). H⁺-ATPase activity in crude homogenates of fish gill tissue – inhibitor sensitivity and environmental and hormonal regulation. *J. Exp. Biol.* **180**, 163-174.
- Lin, C. H., Pfeiffer D. C., Vogl, A.W., Pan, J. and Randall, D. J.** (1994). Immunolocalization of H⁺-ATPase in the gill epithelial of Rainbow trout. *J. Exp. Biol.* **195**, 169-183.
- Lin, C., Lin, L., Hsu, H., Thermes, V., Prunet, P., Horng, J. and Hwang, P.** (2012). Acid secretion by mitochondrion-rich cells of medaka (*Oryzias latipes*) acclimated to acidic freshwater. *Am. J. Physiol. Regul. Intergr. Comp. Physiol.* **302**, 283-291.
- Ma, B., Xiang, Y. and An L.** (2011). Structural bases of physiological function and roles of the vacuolar H⁺-ATPase. *Cell Sign.* **23**, 1244-1256.
- Maetz, J. and Garcia-Romeu, F.** (1964). The mechanism of sodium and chloride uptake in the gills of a fresh-water fish, *Carassius auratus*. *J. Gen. Physiol.* **47**, 1209-1227.

- Malakooti, J., Dahdal, R. Y., Schmidt, L. Layden, T. J., Dudeja, P. K. and Ramaswamy, K.** (1999). Molecular cloning, tissue distribution and functional expression of the human Na⁺/H⁺ exchanger NHE2. *Am. J. Physiol.* **277**, G383-G390.
- McCracken, G. F., Parker, C. R. and Guffey S. Z.** (1993). Genetic differentiation and hybridization between stocked hatchery and native brook trout in Great Smoky Mountains National Park. *Trans. Am. Fish.* **112**, 533-542.
- Mitchell, M. J., Mayer, B., Bailey, S. W., Hornbeck, J. W., Alewell, C., Driscoll, C. T. and Likens, G. E.** (2001). Use of stable isotope ratios for evaluating sulfur sources and losses at the Hubbard Brook experimental forest. *Water Air Soil Pollut.* **130**, 75-86.
- Neff, K. J., Schwartz, J. S., Henry, T. B., Robinson, R. B., Moore, S. E. and Kulp, M A.** (2009). Physiological stress in native southern brook trout during episodic stream acidification in the Great Smoky Mountains National Park. *Arch. Environ. Contam. Toxicol.* **57**, 366-376.
- Newman, K. and Dolloff, A.** (1995). Responses of Blacknose dace (*Rhinichthys atratulus*) and Brook char (*Salvelinus fontinalis*) to acidified water in a laboratory setting. *Water Air Soil Pollut.* **85**, 371-376.
- Orlowski, J. and Grinstein, S.** (2004). Diversity of the mammalian sodium/proton exchanger SLC9 gene family. *Eur. J. Physiol.* **447**, 549-565.
- Perry, S. F., Beyers, M. L. and Johnson, D. A.** (2000). Cloning and molecular characterisation of the trout (*Oncorhynchus mykiss*) vacuolar H⁺-ATPase B subunit. *J. Exp. Biol.* **203**, 459-470.
- Perry, S. F. and Gilmour, K. M.** (2002). Sensing and transfer of respiratory gases at the fish gill. *J. Exp. Zoo.* **293**, 249-263.
- Perry, S. F., Shahsavarani, A., Georgalis, T., Bayaa M., Furimsky, M. and Thomas, S. L.** (2003). Channels, pumps, and exchangers in the gill and kidney of freshwater fishes: their role in ionic and acid-base regulation. *J. Exp. Zoo.* **300**, 53-62.
- Perry, S. F. and Gilmour, K. M.** (2006). Acid-base balance and CO₂ excretion in fish: Unanswered questions and emerging models. *Resp. Physiol. Neurobiol.* **154**, 199-215.
- Reynolds, J. B.** (1996). Electrofishing. In *Fisheries Techniques* (2nd edition). American Fisheries Society, Bethesda, MD.

- Schultheis, P. J., Clarke, L. L., Meneton, P., Meneton, P., Miller, M. L., Soleimani, M., Gawenis, L. R., Riddle, T. M., Duffy, J. J., Doetschman, T., Wang, T., Giebisch, G., Aronson, P. S., Lorenz, J. N. and Shull, G. E.** (1998). Renal and intestinal absorptive defects in mice lacking the NHE3 Na⁺/H⁺ exchanger. *Nature Genet.* **19**, 282-285.
- Slepkov, E. R., Rainey, J. K., Li, X., Lio, Y., Cheng, F. J., Lindout, D. A., Sykes, B. D. and Fliegel, L.** (2005). Structural and functional characterization of transmembrane segment IV of the NHE1 isoform of the Na⁺/H⁺ exchanger. *J. Biol. Chem.* **280**, 17863-17872.
- Sullivan, G. V., Fryer, J. N., Sykes, B. D. and Perry, S. F.** (1995). Immunolocalization of proton pumps (H⁺-ATPase) in pavement cells of rainbow trout gill. *J. Exp. Biol.* **198**, 2619-2629.
- Supek, F., Supekova, L., Mandiyan, S., Pan, Y.C., Nelson, H. and Nelson N.** (1994). A novel accessory subunit for vacuolar H⁺-ATPase from chromaffin granules. *J. Bio Chem.* **269**, 24102-24106.
- Tang, Y., McDonald, D. G. and Boutilier, R. G.** (1989). Acid-base regulation following exhaustive exercise – a comparison between freshwater-adapted and seawater-adapted rainbow trout (*Salmo gairdneri*). *J. Exp. Biol.* **141**, 407-418.
- Toei, M., Saum R. and Forgac M.** (2010). Regulation and isoform function of the V-ATPases. *Biochem.* **49**, 4715-4723.
- Touret, N., Poujeol, P. and Counillon, L.** (2001). Second-site revertants of a low-sodium-affinity mutant of the Na⁺/H⁺ exchanger reveal the participation of the TM4 into a highly constrained sodium-binding site. *Biochem.* **40**, 5095-5101.
- Watanabe, S., Niida, M., Maruyama, T. and Kaneko, T.** (2008). Na⁺/H⁺ exchanger isoform 3 expressed in apical membrane of gill mitochondrion-rich cells in Mozambique tilapia *Oreochromis mossambicus*. *Fish. Sci.* **74**, 813-821.
- Wilkins, S. and Forgac, M.** (2001). Three-dimensional structure of the vacuolar ATPase proton channel by electron microscopy. *J. Bio Chem.* **276**, 44064-44068.
- Wilson, J. M., Laurent, P., Tufts, B., Benos, D., Donowitz, M., Vogl, A. and Randall, D.** (2000a). NaCl uptake by the branchial epithelium in freshwater teleost fish: an immunological approach to ion-transport protein localization. *J. Exp. Biol.* **203**, 2279-2296.
- Wilson, J. M., Randall D. J., Donowitz, M., Vogl, A. W. and IP, A. K.** (2000b). Immunolocalization of ion transport proteins to the branchial epithelium mitochondria-rich cells in the mudskipper (*Periophthalmodon schlosseri*). *J. Exp. Biol.* **203**, 2297-2310.

Wormmeester, L., Sancesz de Medina, F., Kokke, F., Tse, C. M., Khurana, S., Bowser, J., Cohen, M. E. and Donowitz, M. (1998). Quantitative contribution of NHE2 and NHE3 to rabbit ileal brush-border Na^+/H^+ exchange. *Am. J. Physiol.* **274**, C1261-C1272.

Yan, J. J., Chou, M. Y., Kaneko, T. and Hwang, P. P. (2007). Gene expression of Na^+/H^+ exchanger in zebrafish H^+ -ATPase-rich cells during acclimation to low- Na^+ and acidic environments. *Am. J. Physiol. Cell Physiol.* **293**, 1814-1823.

Zhang, Z., Zheng, Y., Mazon, H., Milgrom, E., Kitagawa, N., Kish-Trier, E., Heck, A. J. R., Kane, P. M. and Wilkens S. (2008). Structure of the yeast vacuolar ATPase. *J. Biochem.* **51**, 35983-35995.

VITA

Brian Mikeworth was born to Kevin and Laura Mikeworth in Bel Air, Maryland where he spent the first six years of his life. During the summer of 1994, he and his family moved to Huntersville, North Carolina, where he completed primary school. Following graduation from Hopewell High School in the summer of 2006, Brian attended Appalachian State University following his interests by studying Biology with a concentration in Ecology. Brian first met Dr. Sue Edwards through the Human Systems Physiology class he attended in the summer of 2009, where he became interested in comparative physiology. He followed this interest by working in Dr. Edwards' research laboratory primarily focusing on RNA isolation techniques from the sea lamprey. Finally, in 2010 he received his bachelor's degree in Biology with a concentration in Ecology with prospects of attending graduate school at Appalachian State University in the Fall of 2010.

Brian entered the graduate school in the Department of Biology under Dr. Edwards where he originally planned on studying ion-transport mechanisms in the Atlantic hagfish, *Myxine glutinosa*. This changed in January of 2011, where Dr. Edwards stumbled across the southern brook trout, *Salvelinus fontinalis* and its ability to survive rather acidic stream conditions. After a phone call and meeting with the Fisheries Department in the GRSM, Dr. Edwards and Brian began work on this project. After two years of hard work, Brian received his Master's of Science degree from Appalachian State University. He is currently perusing a career with Duke Energy working in the Environmental, Health and Safety Department.